

1SLI PROFILE

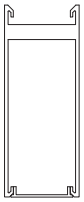

2SLI PROFILE

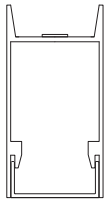

4SLI PROFILE

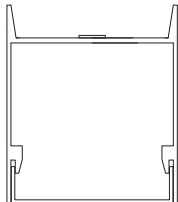

included Component

Standalone Fixtures (2' to 8')

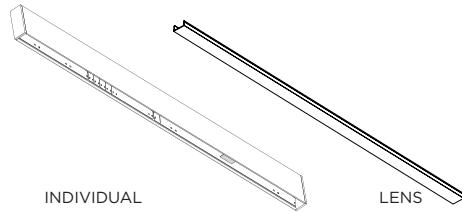

Two Section Fixtures (9' to 16')

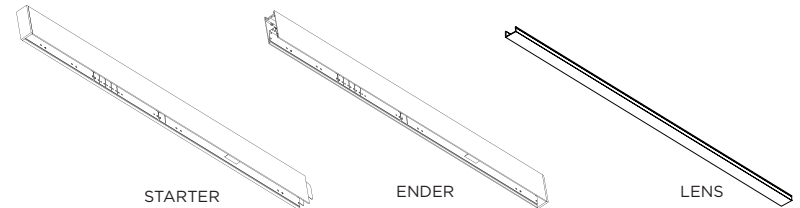

Multi-Section Fixtures (17' and longer)

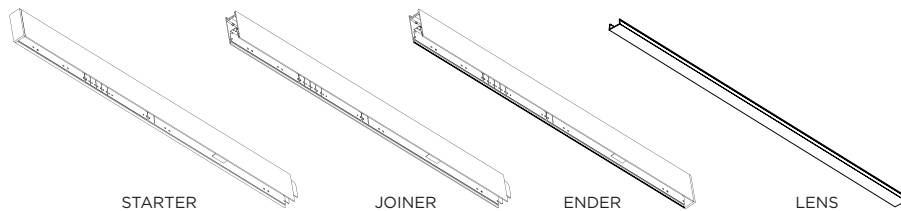

Component

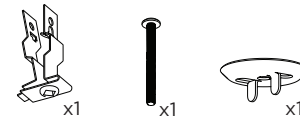

INSTRUCTION KEY

INFORMATION

- ADDITIONAL
INSTALLATION SHOULD ONLY BE PERFORMED BY A CERTIFIED ELECTRICIAN
REFER TO LOCAL/NATIONAL CODES FOR PROPER INSTALLATION
- ATTENTION
FAILURE TO FOLLOW INSTALLATION INSTRUCTION MAY VOID THE WARRANTY
- POWER ON
DO NOT TOUCH LEDS. LEDS MUST BE PROTECTED FROM MECHANICAL STRESS OR DEBRIS
- POWER OFF
TURN OFF POWER DURING INSTALLATION OR SERVICING

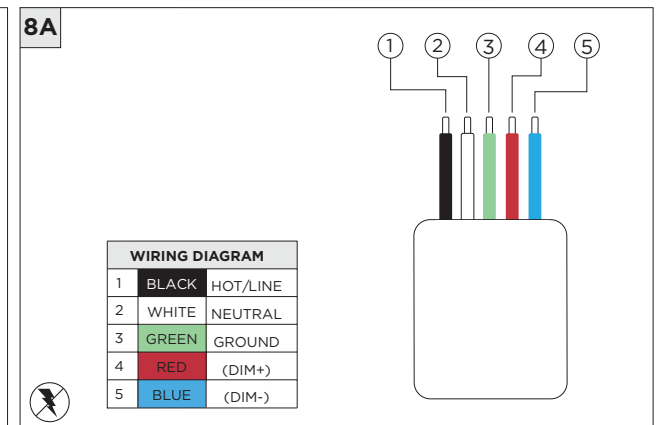
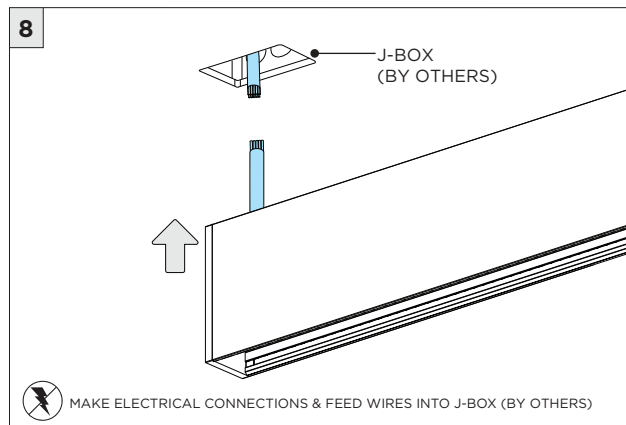
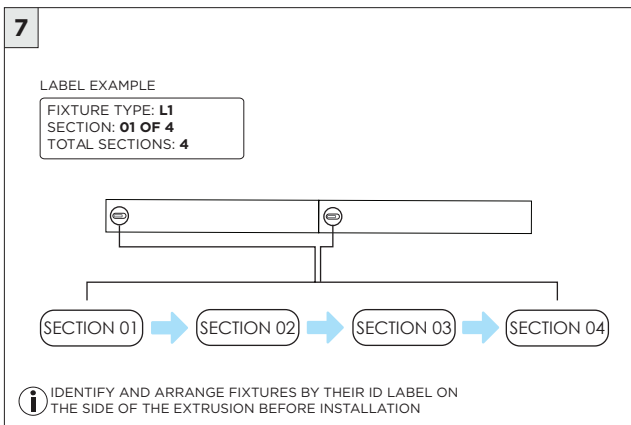
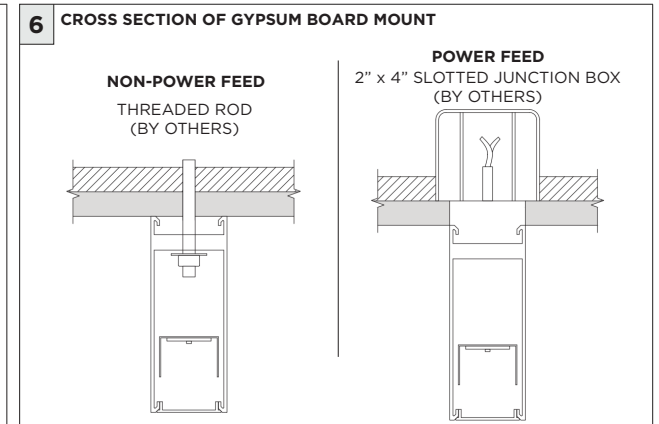
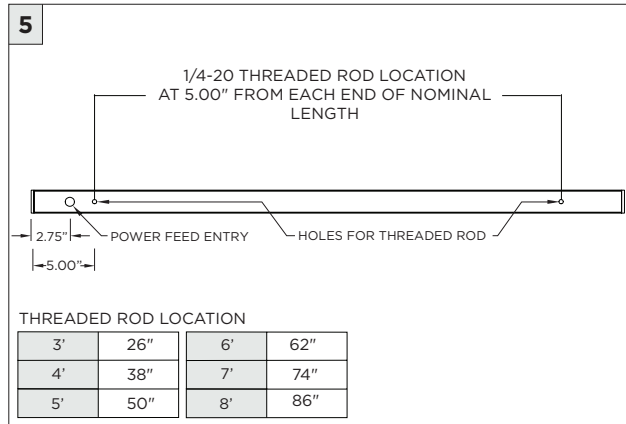
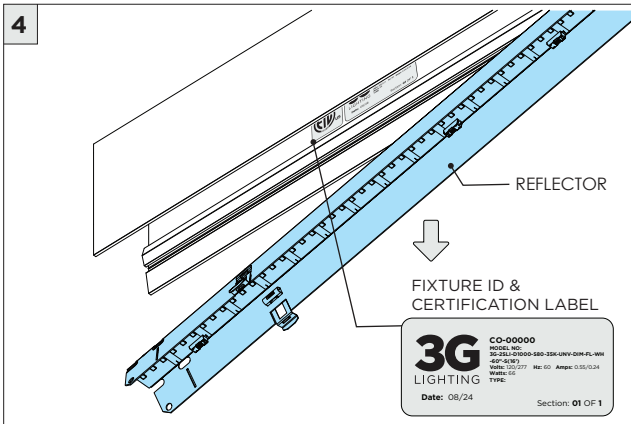
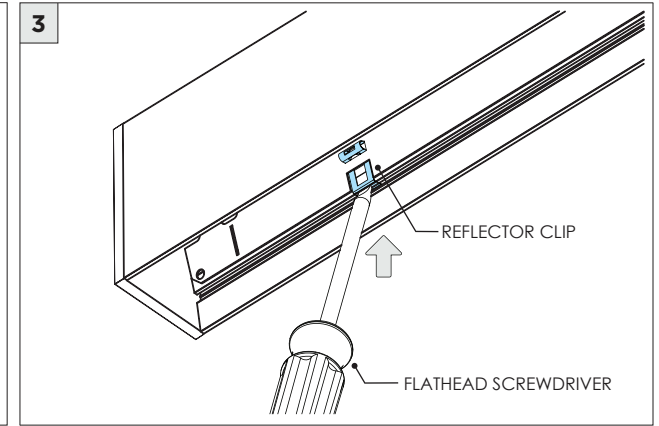
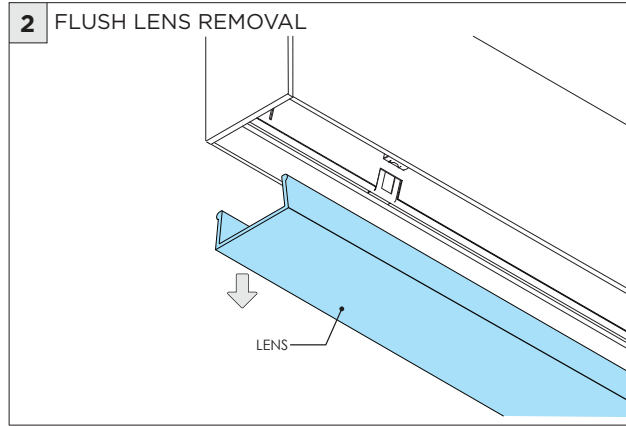
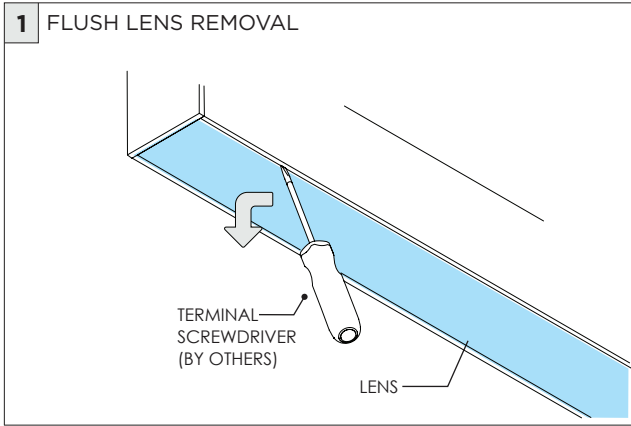

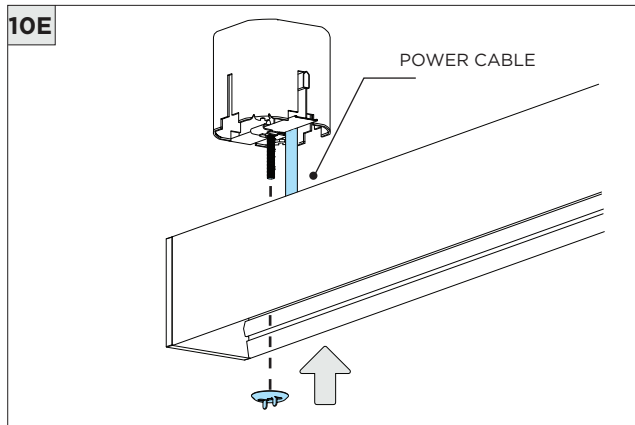
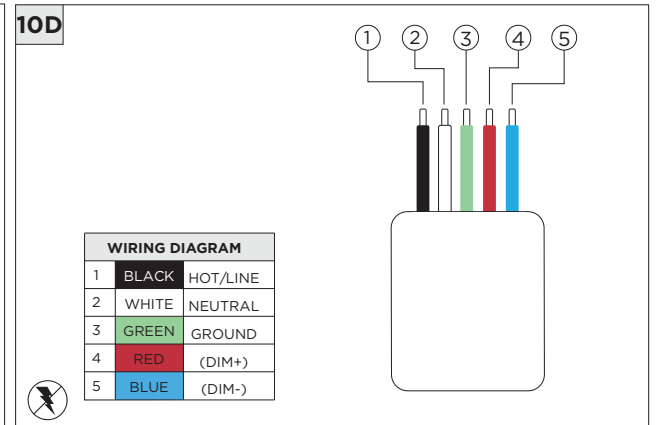
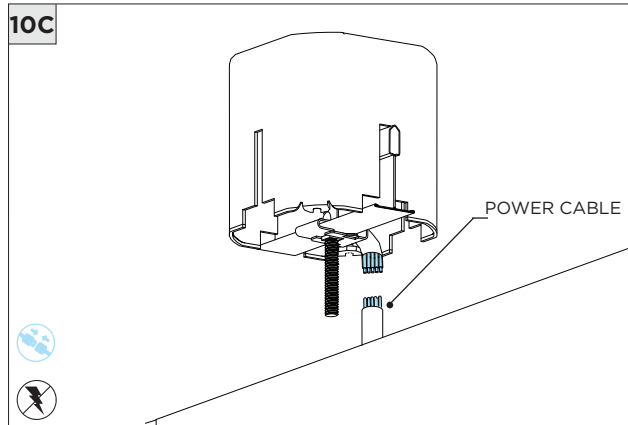
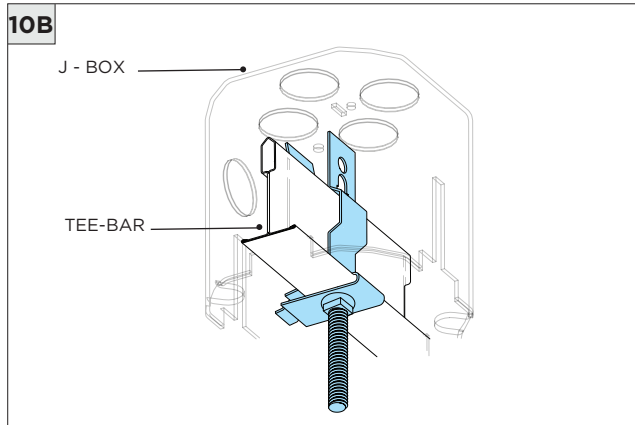
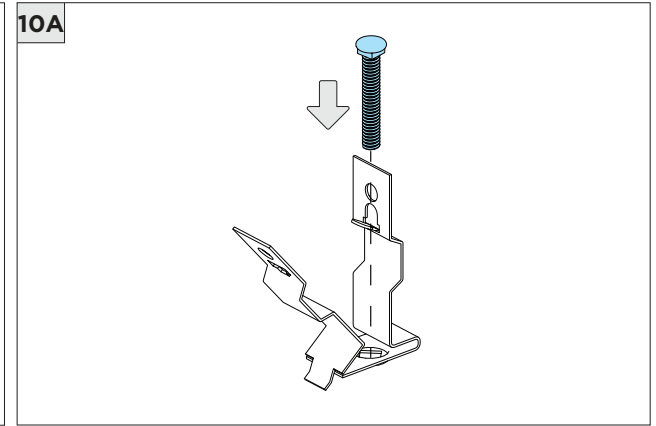
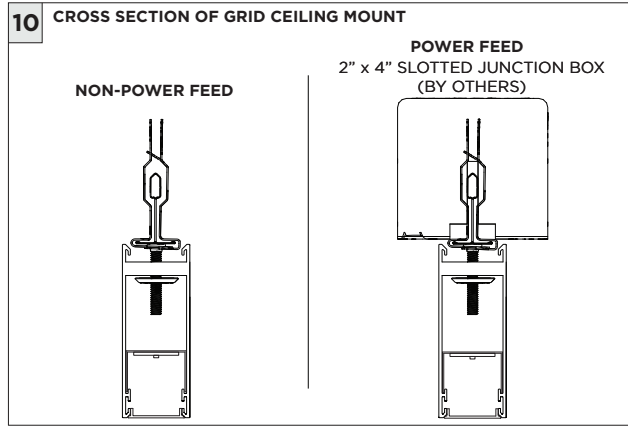
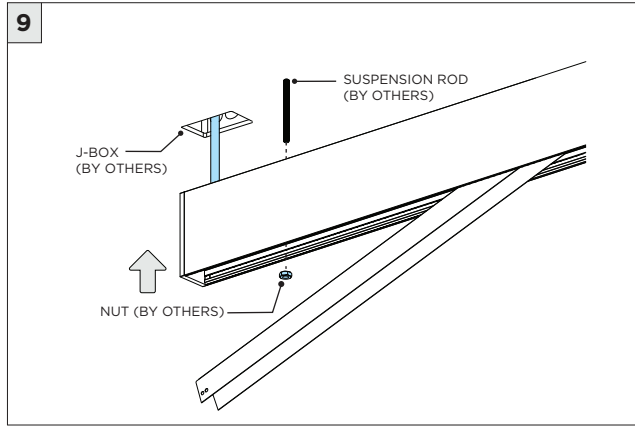

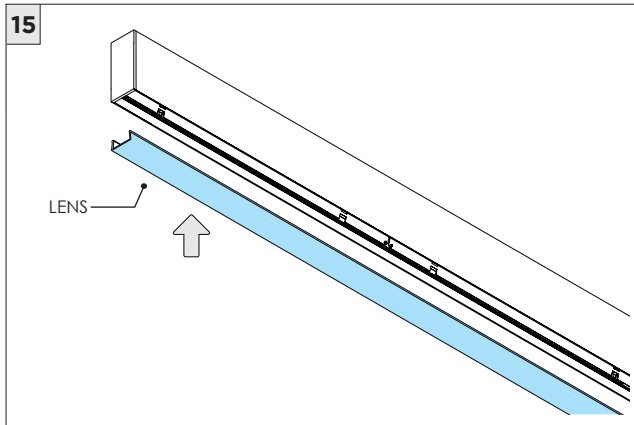
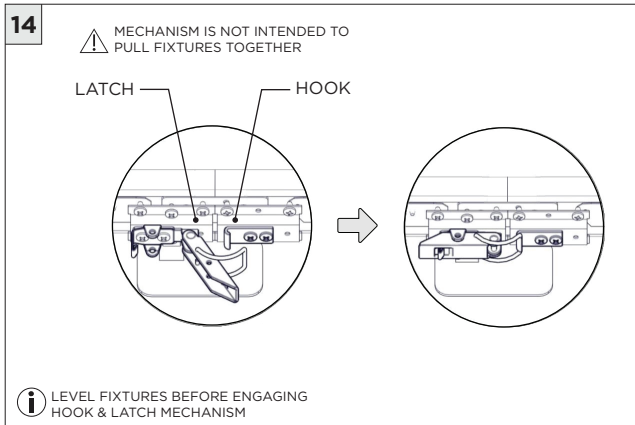
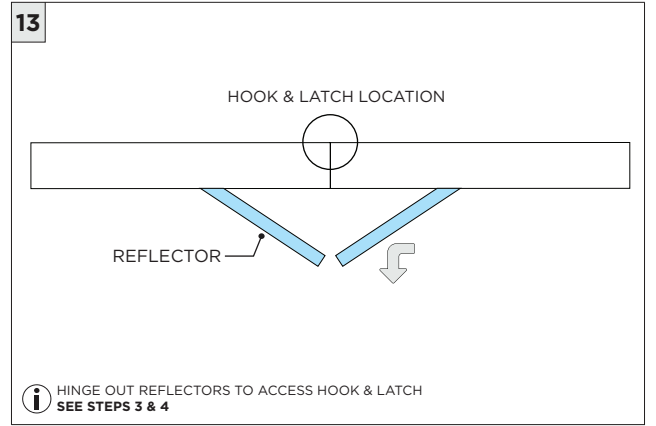
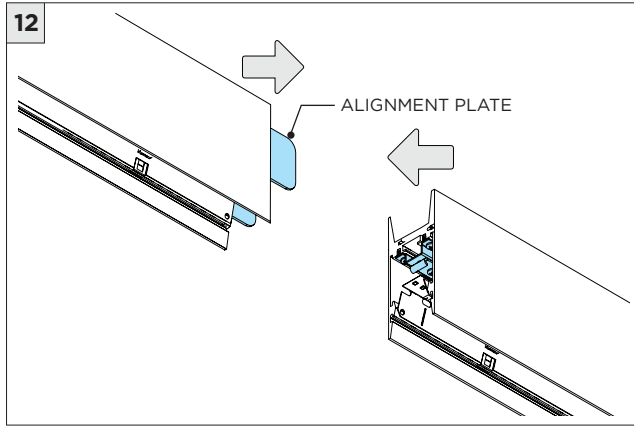
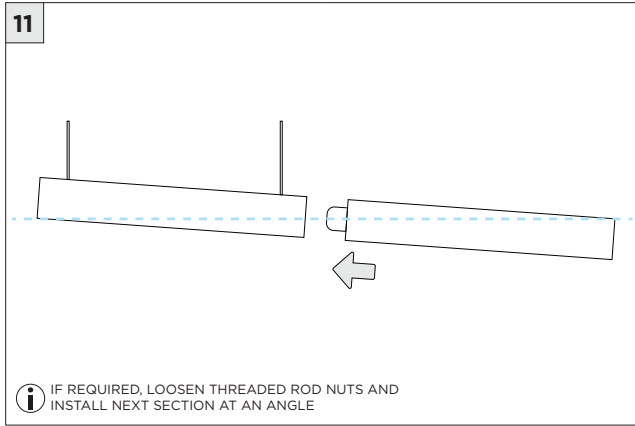

DRIVER SERVICING

1 FLUSH LENS REMOVAL

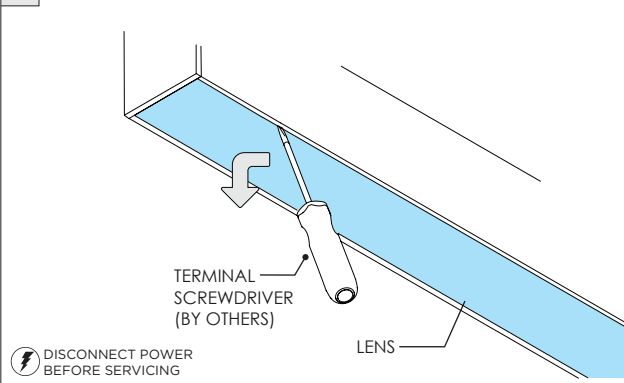

2

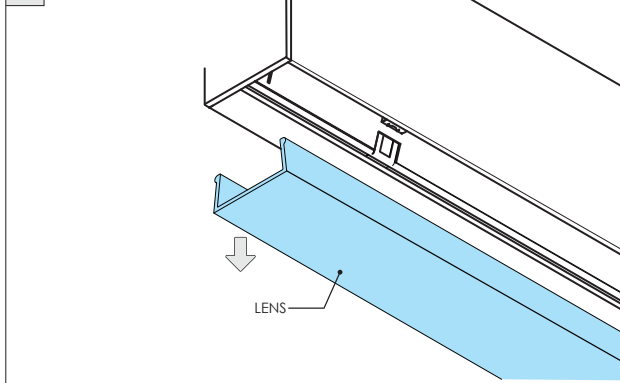

3

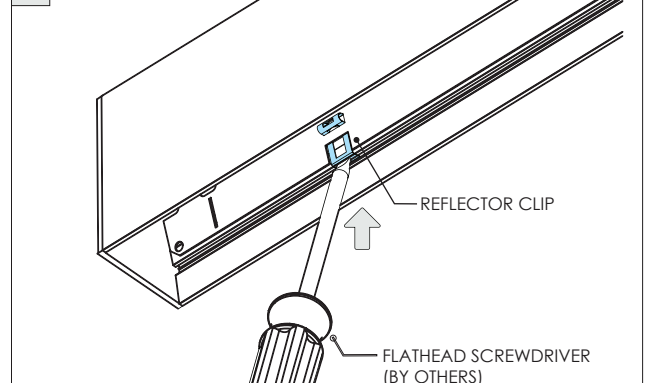

4

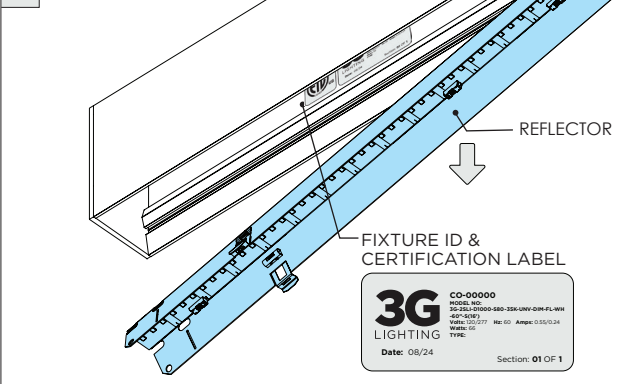

5

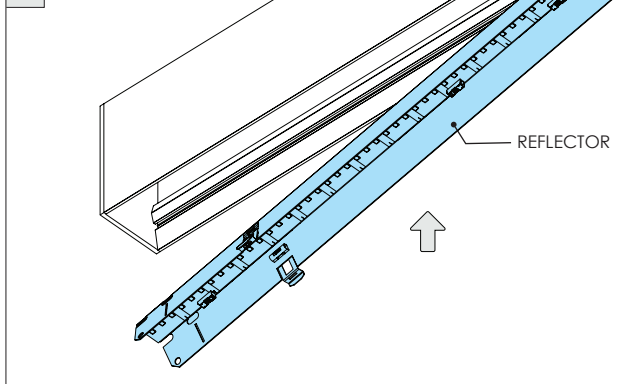

6

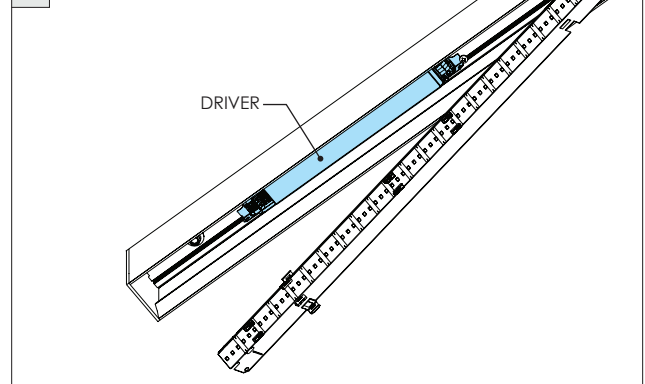

7

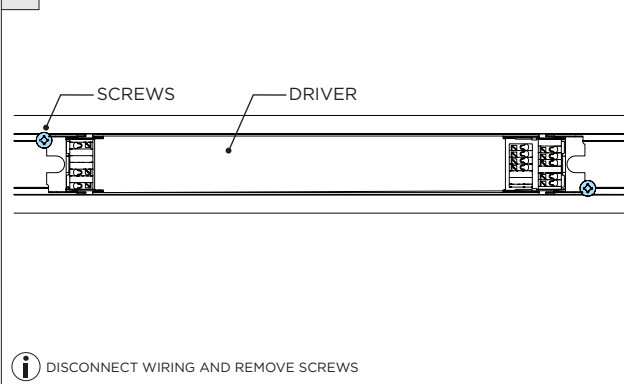

LED SERVICING

