

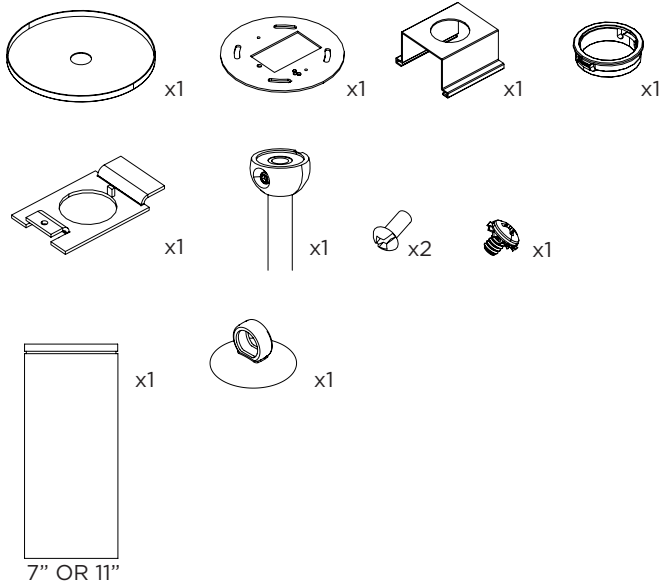

COMPONENTS

STANDARD CANOPY



CONDUIT FEED CANOPY

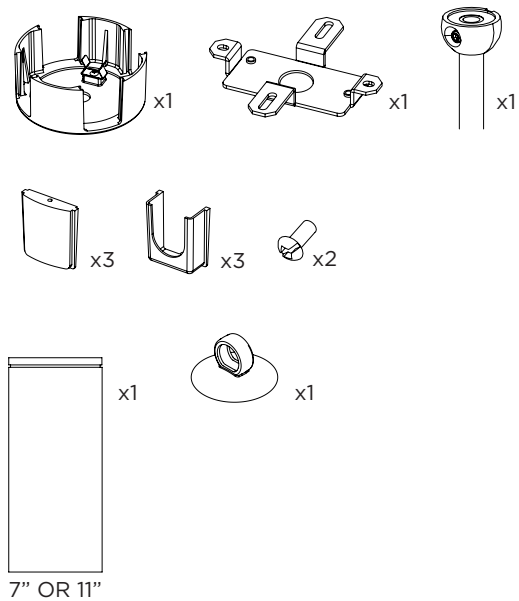

4" OCTAGONAL J-BOX REQUIRED FOR INSTALLATION

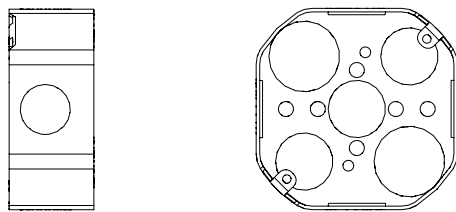

JUNCTION BOX (BY OTHERS)

SUITABLE FOR SLOPED CEILING

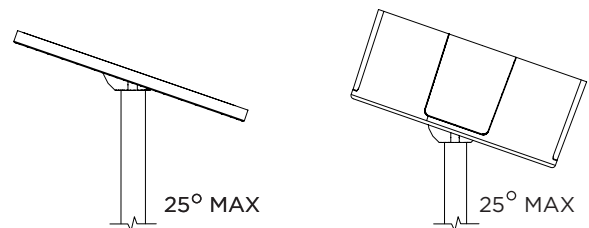

INSTRUCTION KEY

INFORMATION

	ADDITIONAL	<p>INSTALLATION SHOULD ONLY BE PERFORMED BY A CERTIFIED ELECTRICIAN REFER TO LOCAL/NATIONAL CODES FOR PROPER INSTALLATION FAILURE TO FOLLOW INSTALLATION INSTRUCTION MAY VOID THE WARRANTY DO NOT TOUCH LEDS. LEDS MUST BE PROTECTED FROM MECHANICAL STRESS OR DEBRIS TURN OFF POWER DURING INSTALLATION OR SERVICING</p>
	ATTENTION	
	POWER ON	
	POWER OFF	

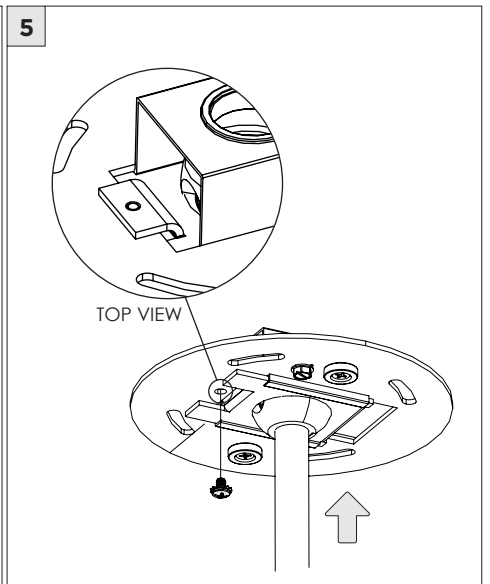
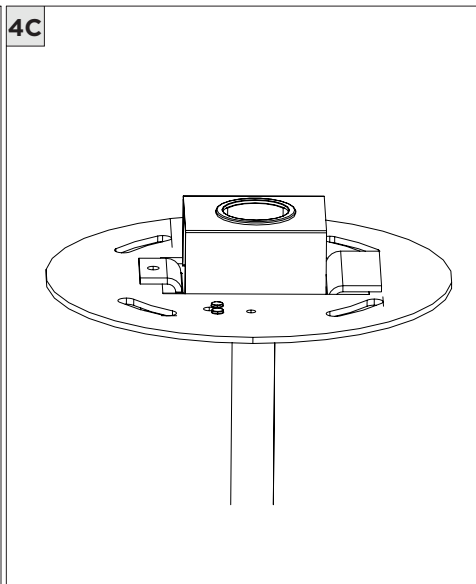
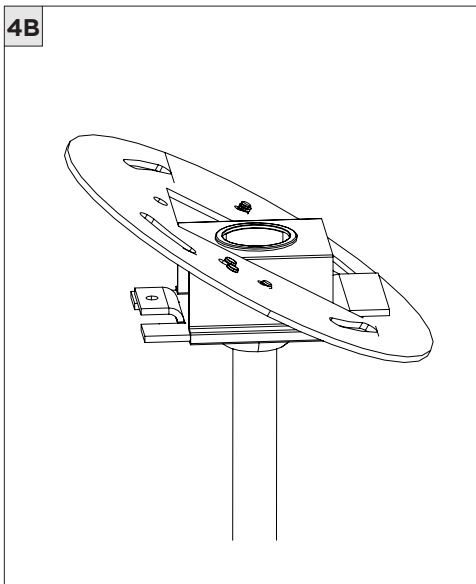
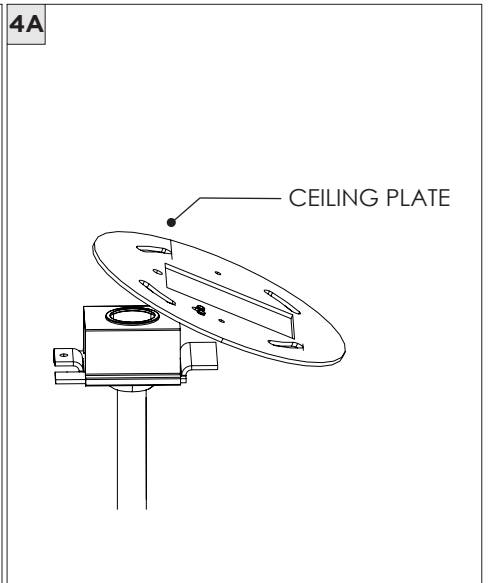
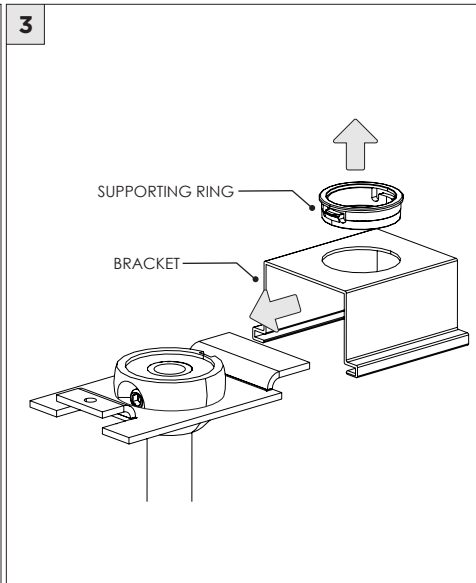
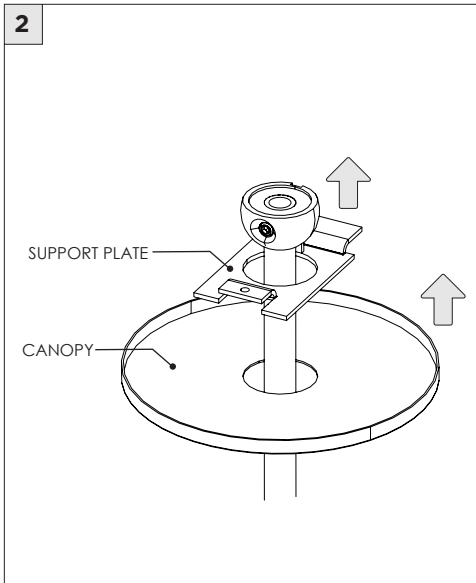
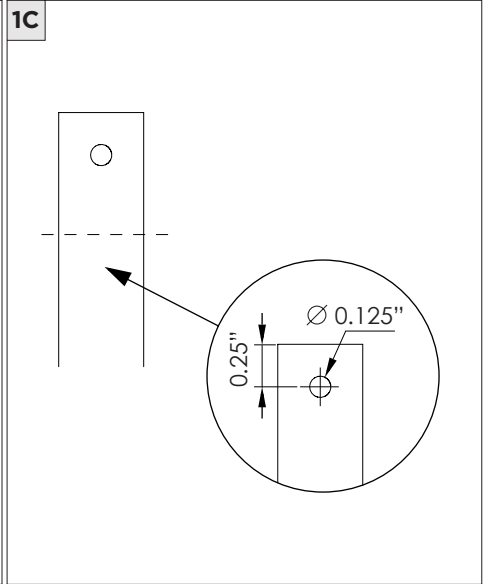
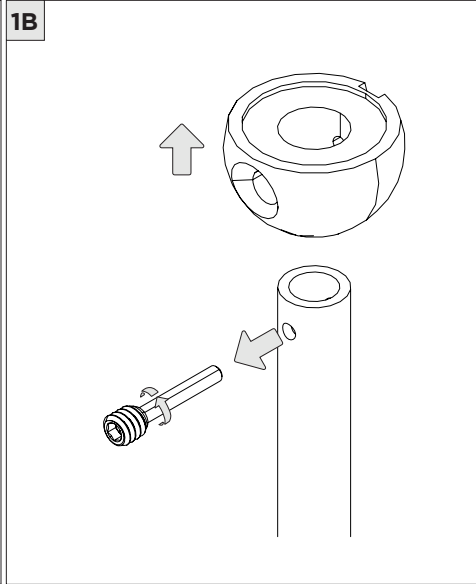
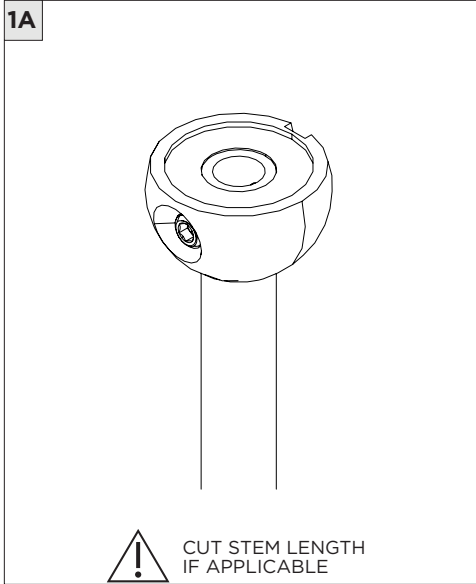

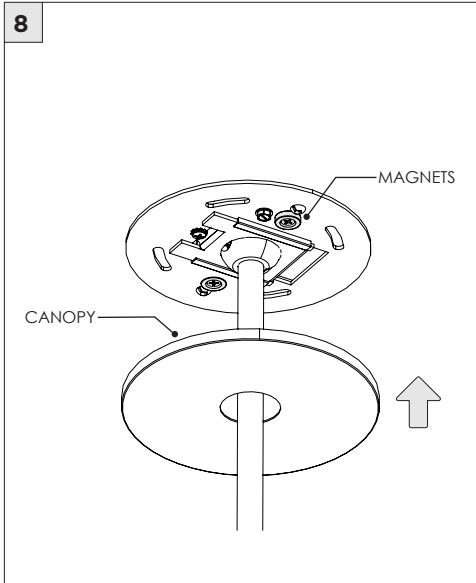
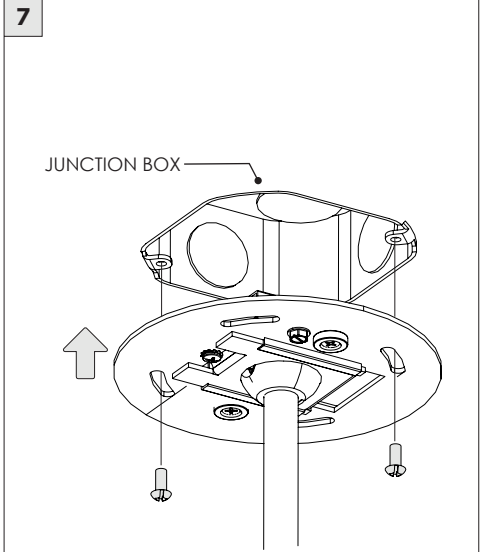
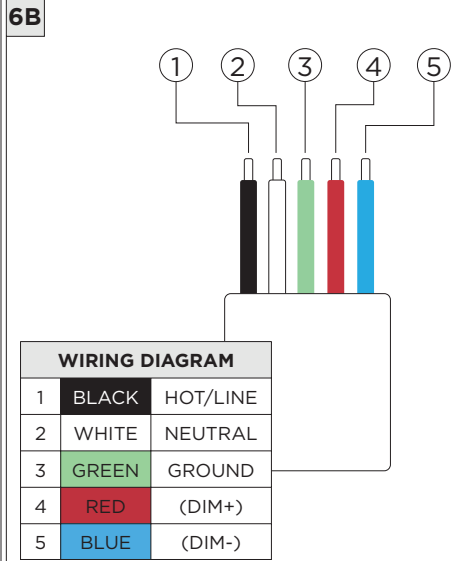
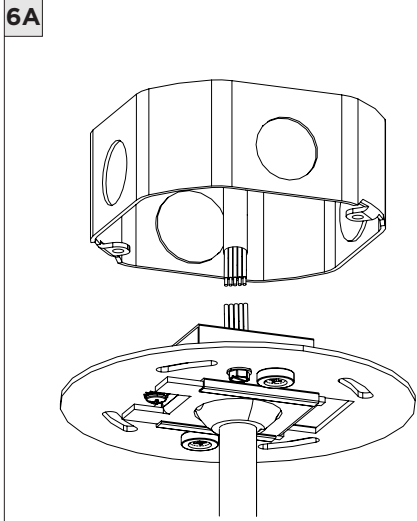

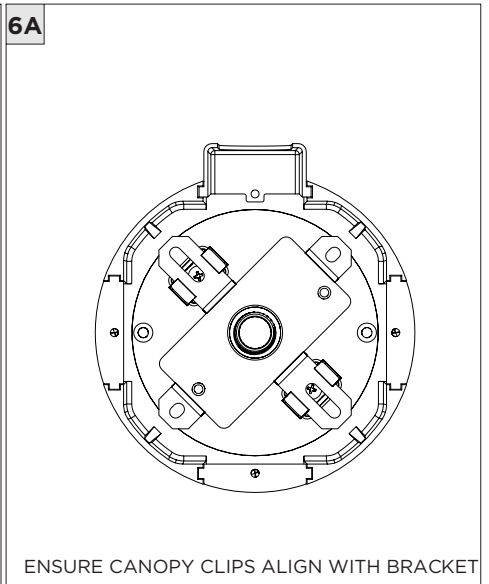
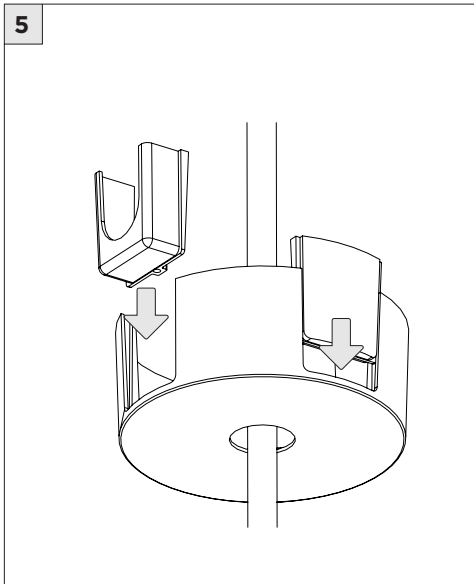
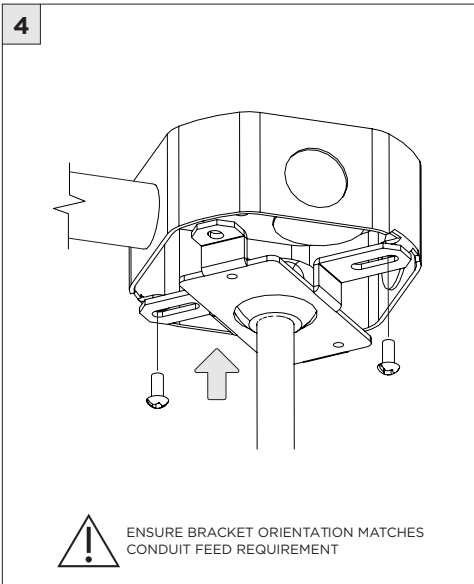
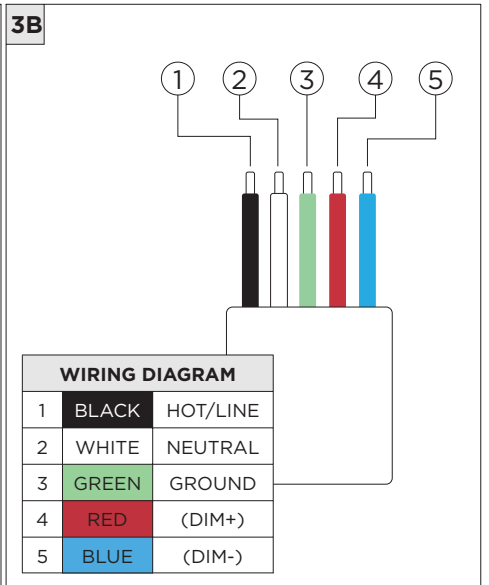
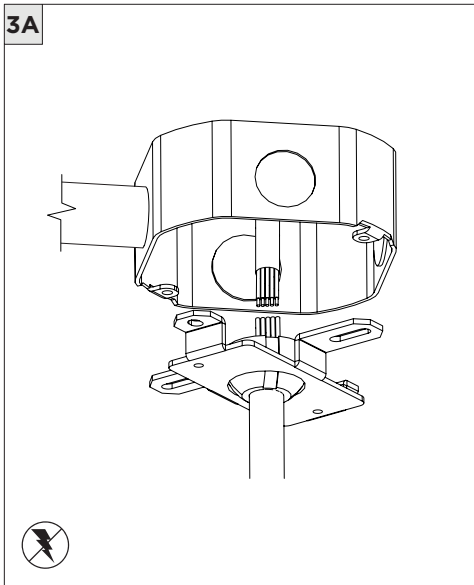
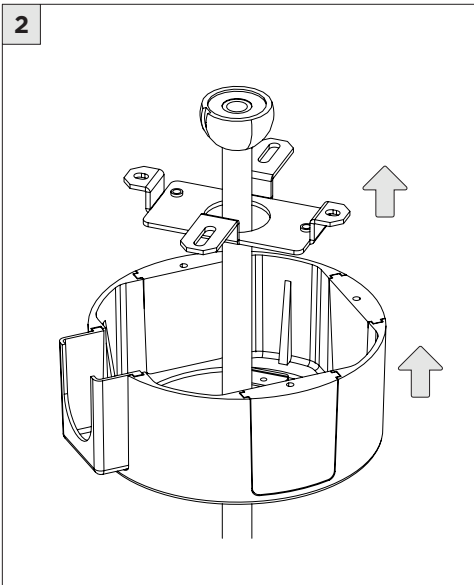
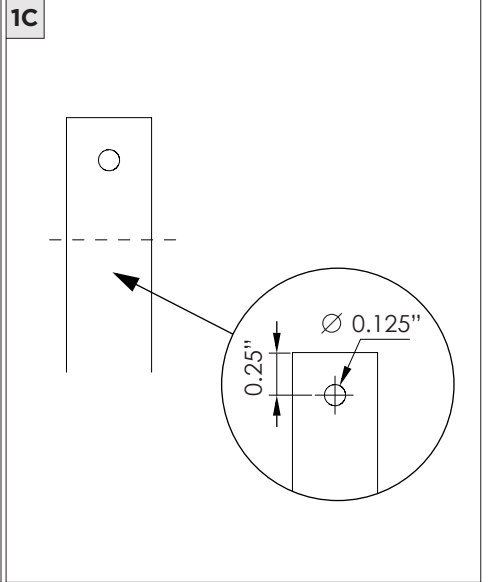
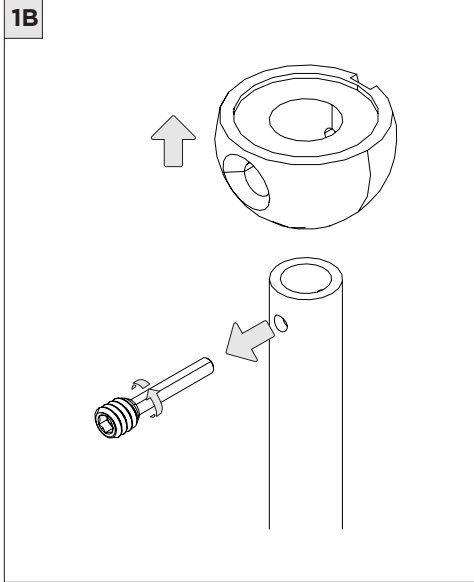
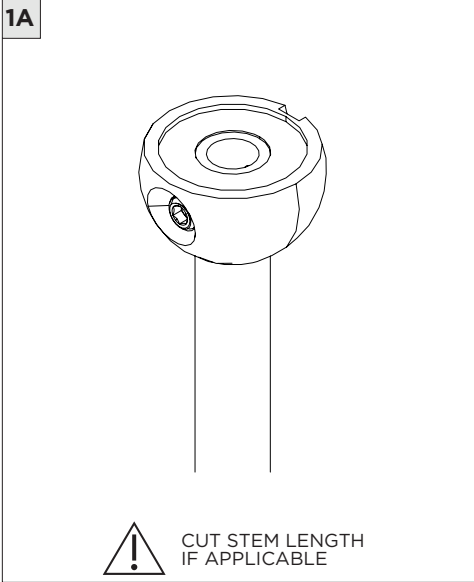

6B

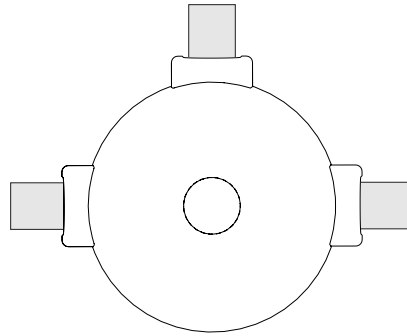
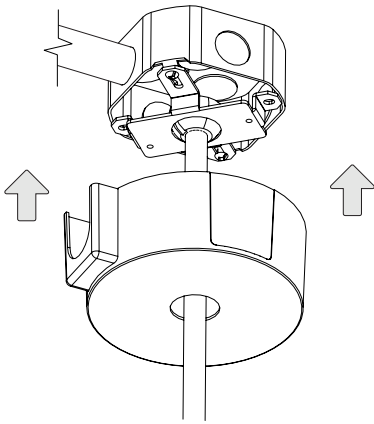

CANOPY IS SUITABLE FOR
MAXIMUM 3 CONDUIT FEEDS

DRIVER SERVICING

1

2

DRIVER

LED SERVICING

1

LOUVER

UNCLIP LOUVER FROM LED ASSEMBLY

2

CENTER CAP

UNCLIP CENTER CAP FROM LED ASSEMBLY

3

LOCATE CENTER SCREW

4

UNSCREW CENTER SCREW TO REMOVE LED ASSEMBLY

5

QUICK-CONNECT CABLE

DISCONNECT QUICK-CONNECT CABLE FROM LED ASSEMBLY

6

QUICK-CONNECT CABLE

CONNECT QUICK-CONNECT CABLE TO NEW LED ASSEMBLY

7

SCREW NEW LED ASSEMBLY INTO CYLINDER

8

CENTER CAP

9

LOUVER