

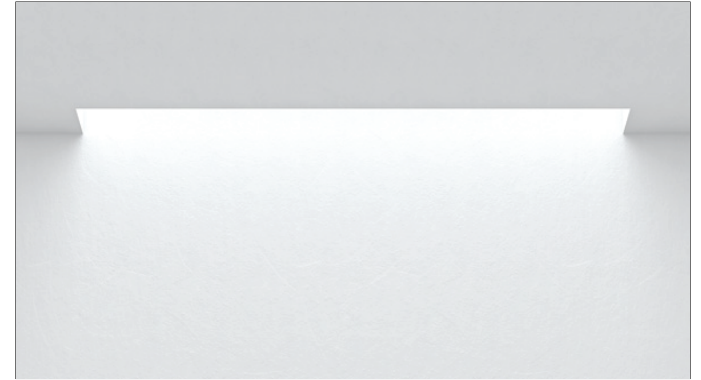

3G-2RPE, 3G-4RPE 2", and 3.5" PERIMETER

FLANGELESS
TRIM FLANGE
TRIMLESS FLANGE



⚠ FOR NEW CONSTRUCTION INSTALLATION ONLY

ⓘ TOOLS AND DRYWALL SCREWS SUPPLIED BY OTHERS

FIXTURE TYPES		INCLUDED COMPONENTS	
<p>2RPE PROFILE 4RPE PROFILE</p>	<p>Standalone Fixtures (2' to 8')</p> <p>INDIVIDUAL LENS J CHANNEL</p>		<p>Continuous Runs (9' to 16')</p> <p>STARTER ENDER LENS J CHANNEL</p>
<p>Continuous Runs (17' and longer)</p> <p>STARTER JOINER ENDER LENS J CHANNEL</p>		<p>End Filler (OPTIONAL)</p> <p>END FILLER</p>	

INSTRUCTION KEY	INFORMATION
⚠ ADDITIONAL	<ul style="list-style-type: none"> • INSTALLATION SHOULD ONLY BE PERFORMED BY A CERTIFIED ELECTRICIAN • REFER TO LOCAL/NATIONAL CODES FOR PROPER INSTALLATION • FAILURE TO FOLLOW INSTALLATION INSTRUCTIONS MAY VOID THE WARRANTY • DO NOT TOUCH LEDS. LEDS MUST BE PROTECTED FROM MECHANICAL STRESS OR DEBRIS • TURN OFF POWER DURING INSTALLATION OR SERVICING • CONTRACTOR IS RESPONSIBLE FOR REINFORCING WALLS/CEILINGS TO SUPPORT FIXTURE WEIGHT • 3G LIGHTING DOES NOT ACCEPT RESPONSIBILITY FOR INADEQUATELY REINFORCED WALLS/CEILINGS
ⓘ ATTENTION	
⚡ POWER ON	
⊘ POWER OFF	

OVERVIEW

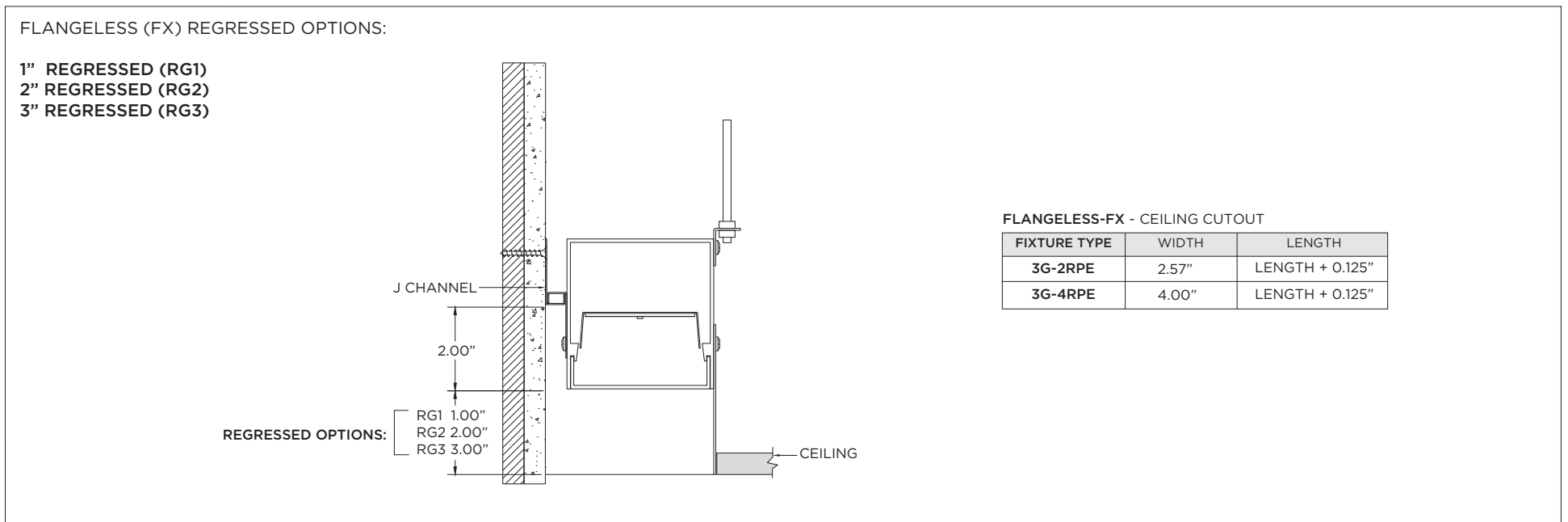
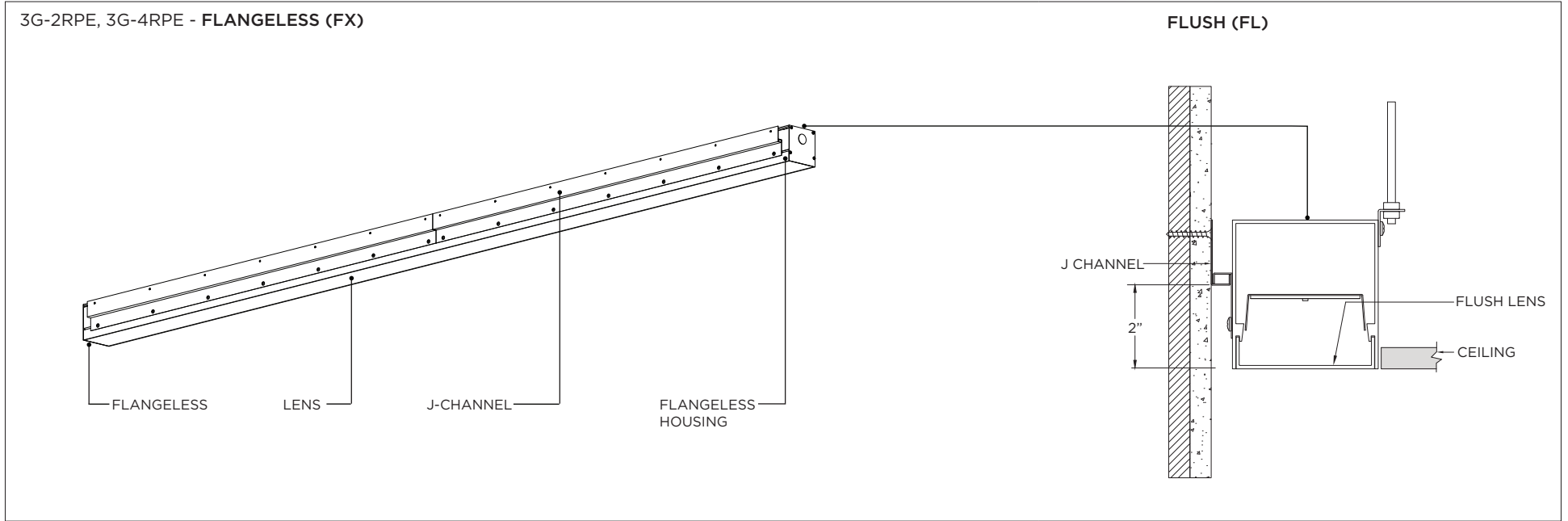

OVERVIEW

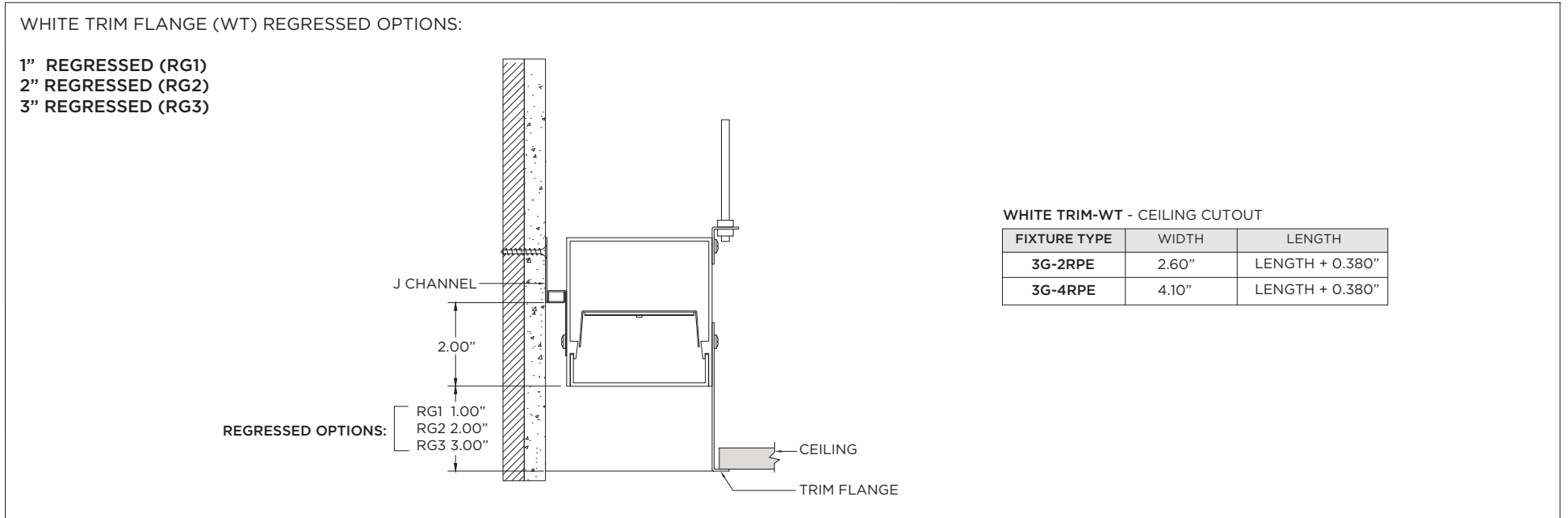
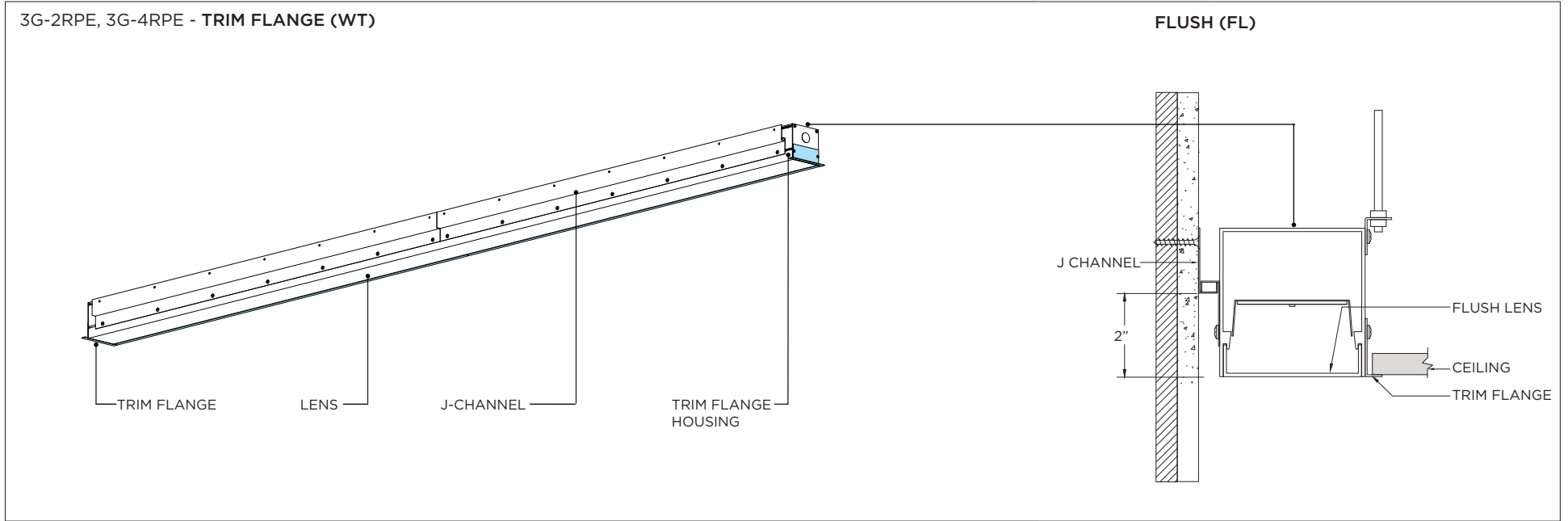

OVERVIEW

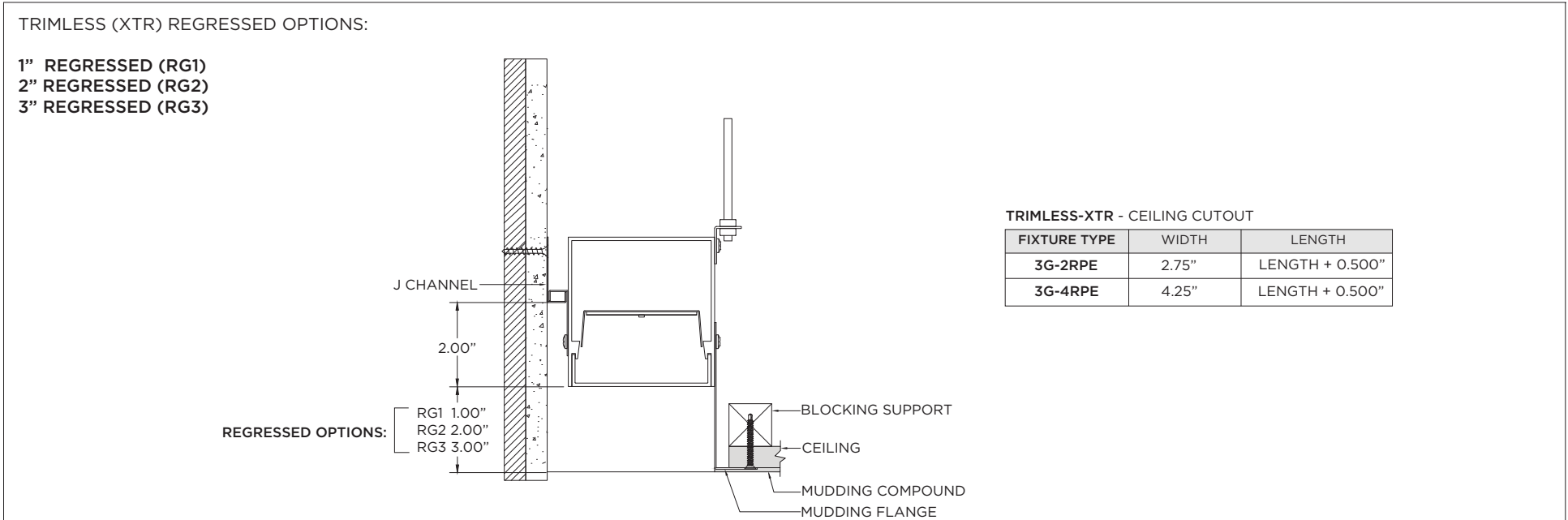
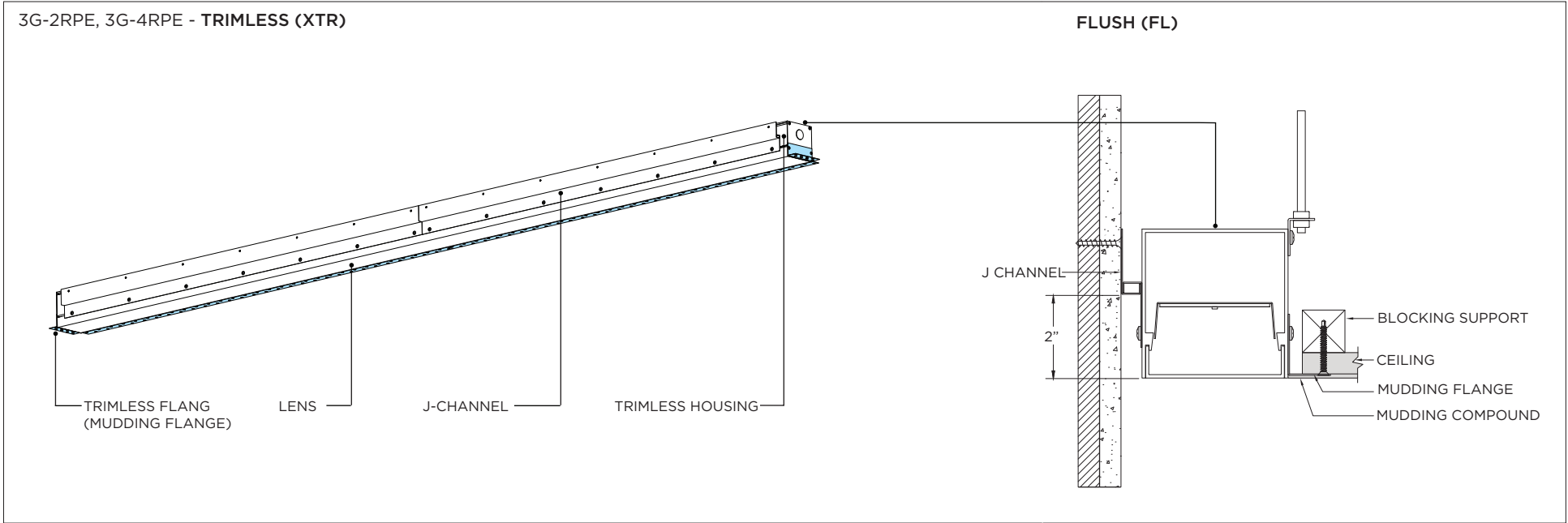

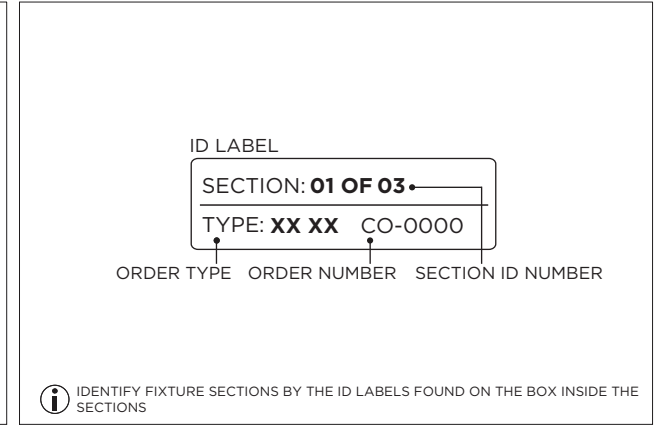
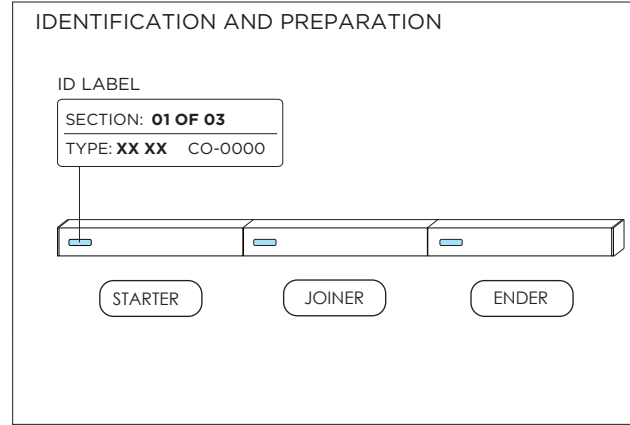
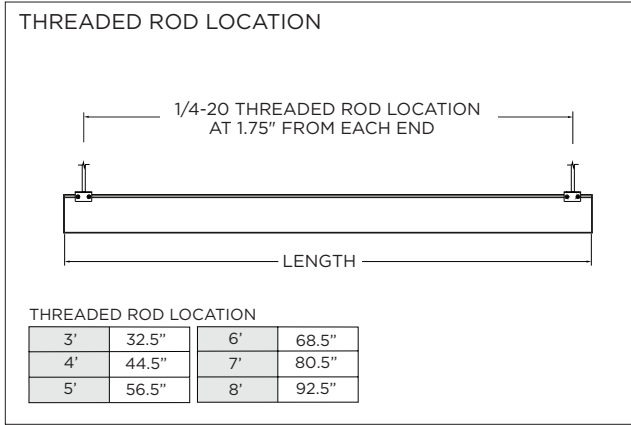

ASYMMETRIC LENS ORIENTATION

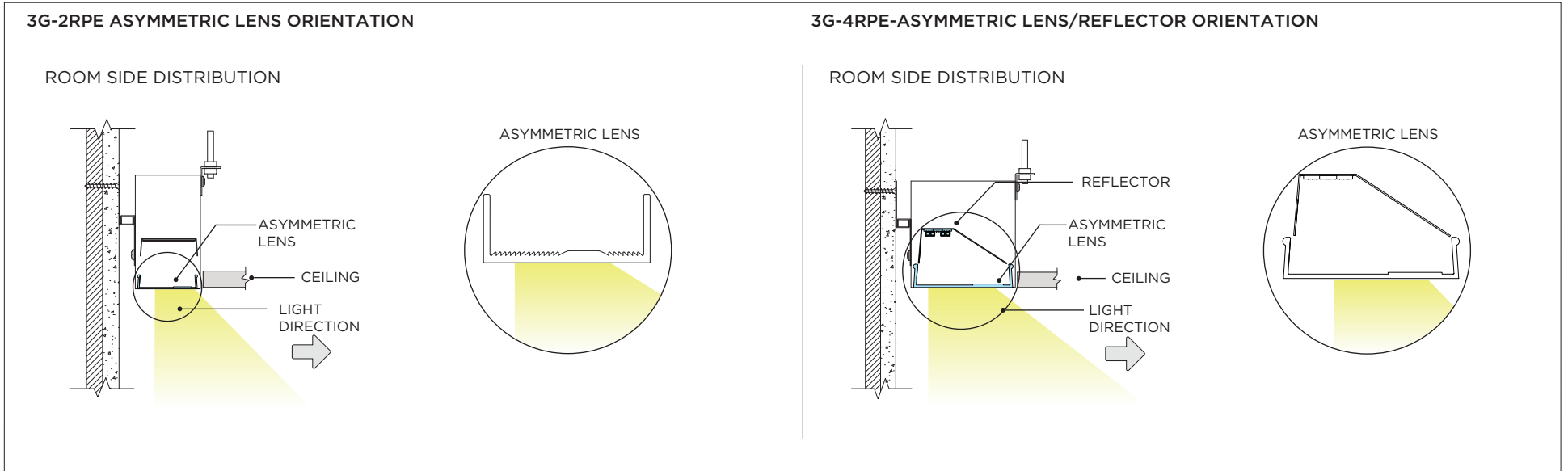

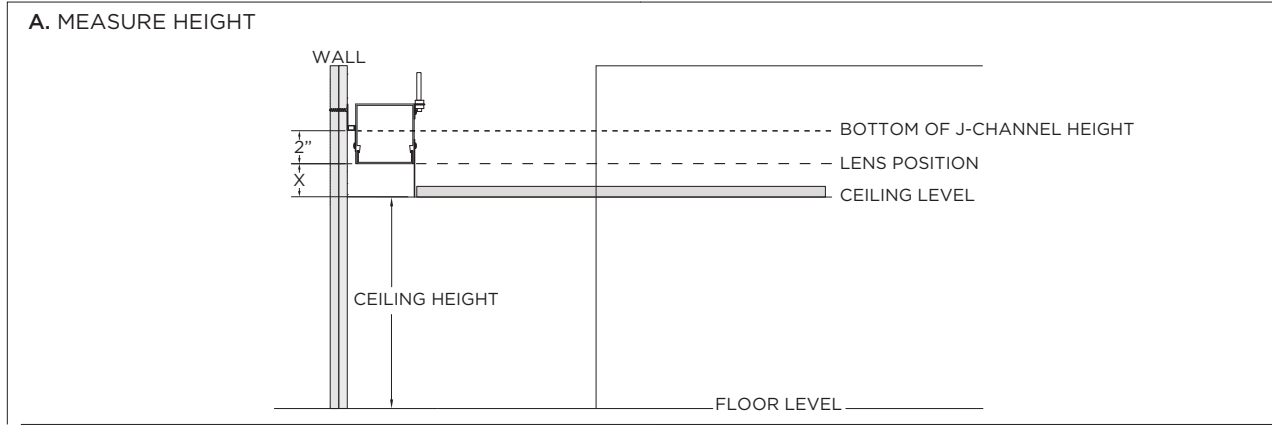

B.

J-CHANNEL HEIGHT

LENS POSITION (X)	BOTTOM OF J-CHANNEL HEIGHT
FL - FLUSH	2" ABOVE CEILING LEVEL
RG1- 1" REGRESSED	3" ABOVE CEILING LEVEL
RG2-2" REGRESSED	4" ABOVE CEILING LEVEL
RG3-3" REGRESSED	5" ABOVE CEILING LEVEL

MOUNTING J-CHANNEL

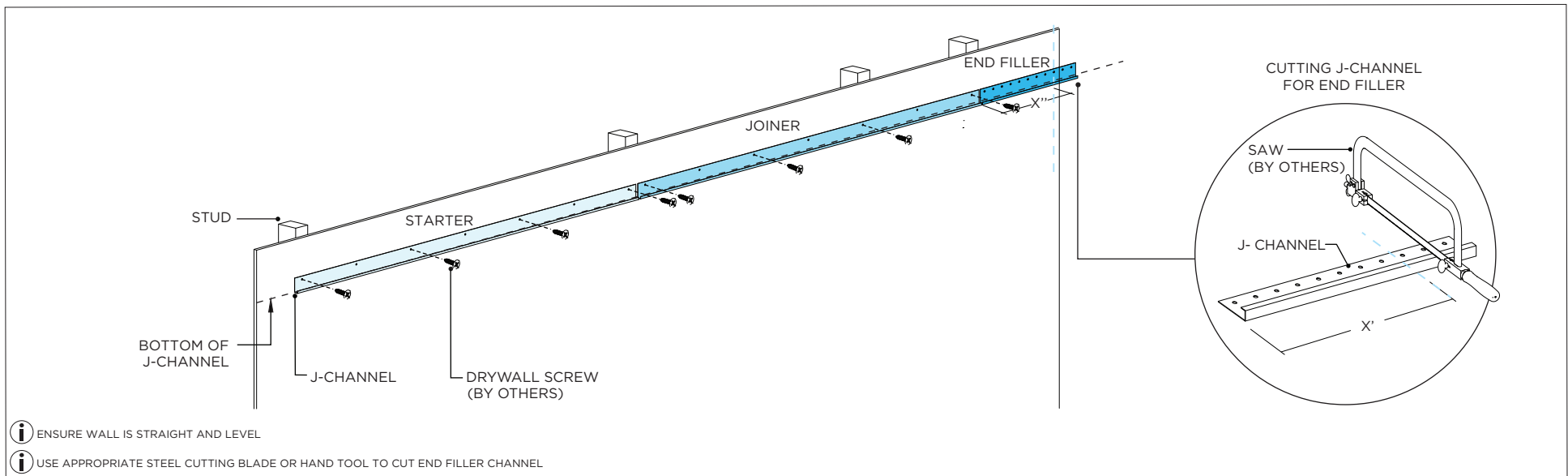

STARTER

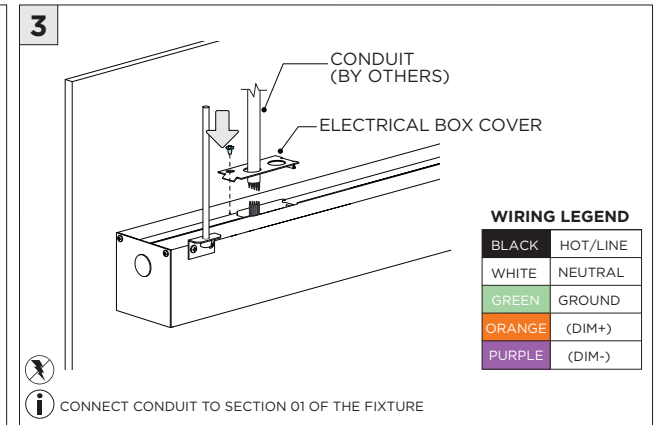
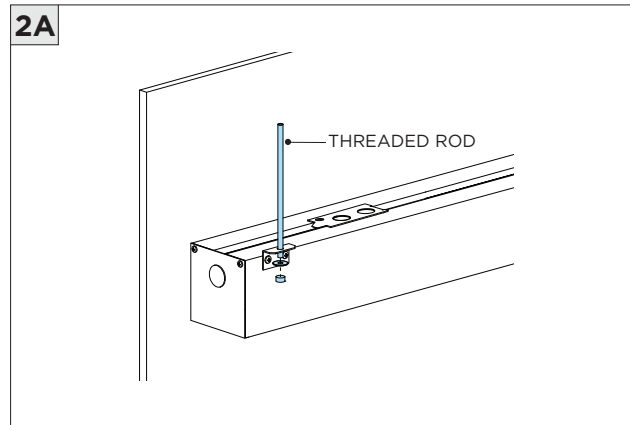
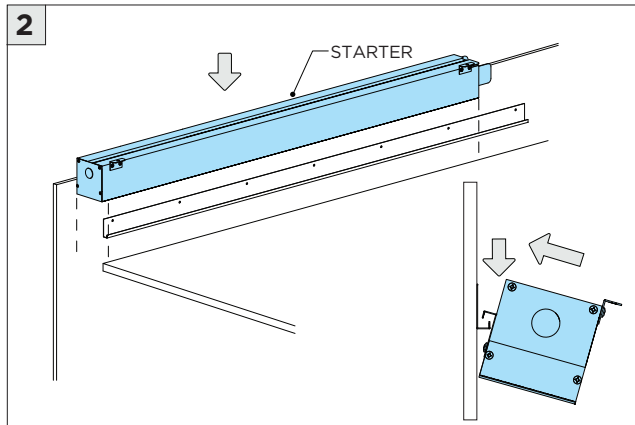
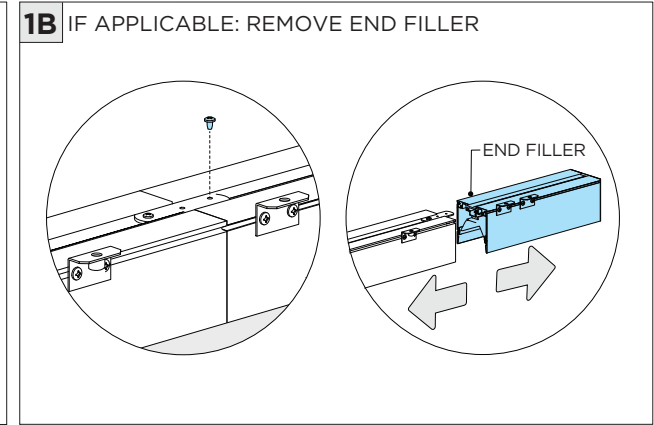
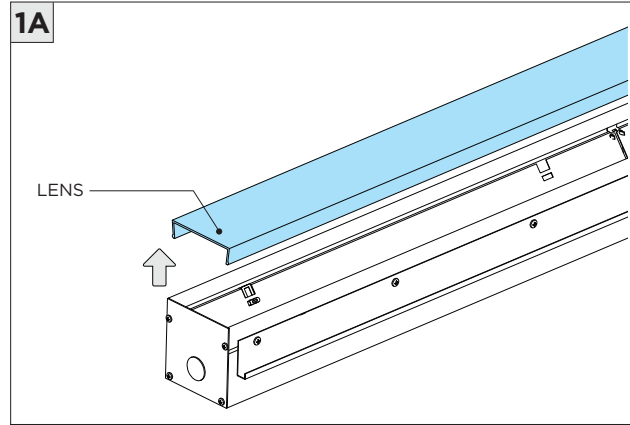
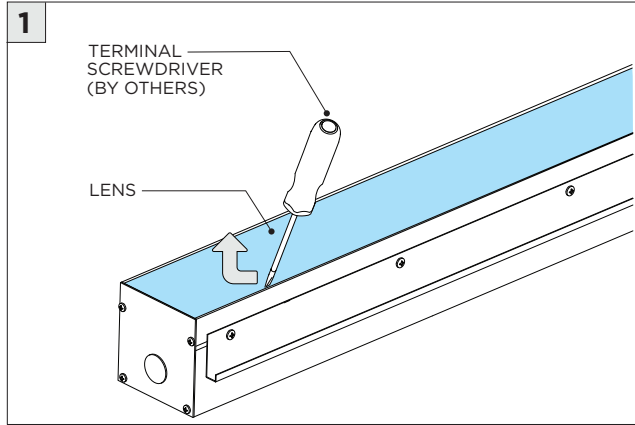

JOINER/ENDER

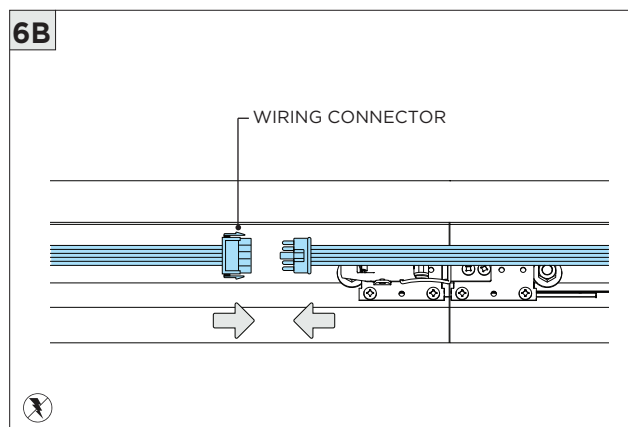
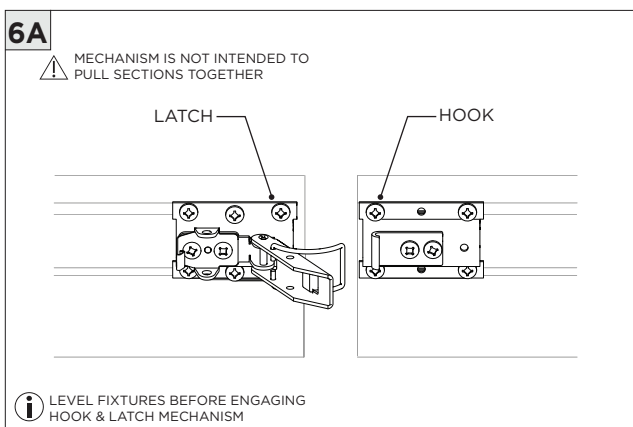
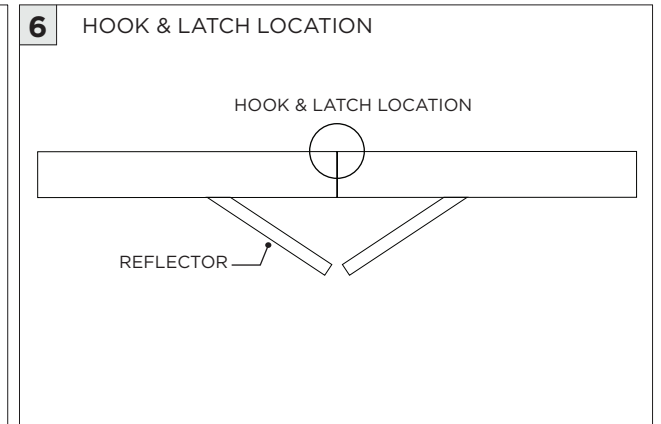
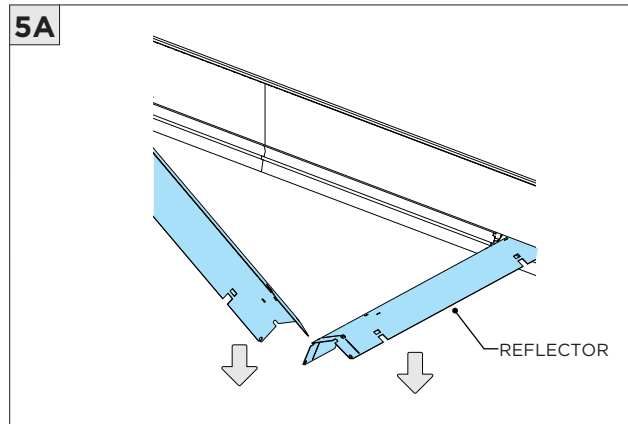
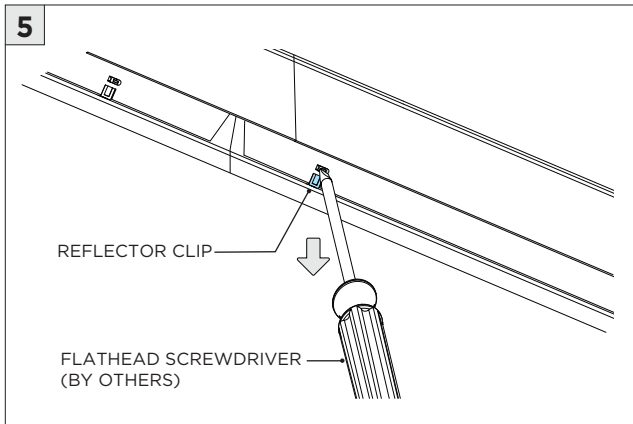
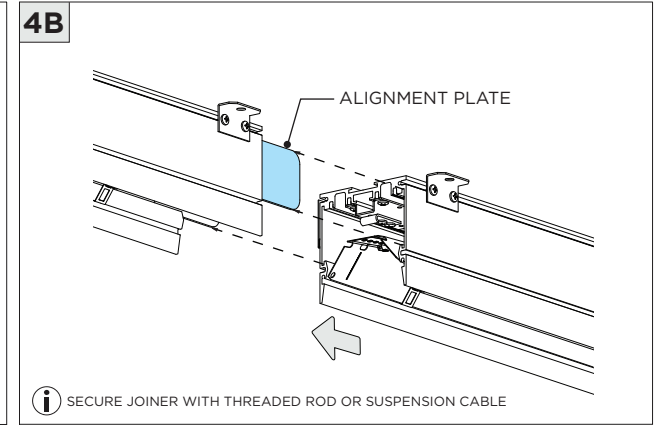
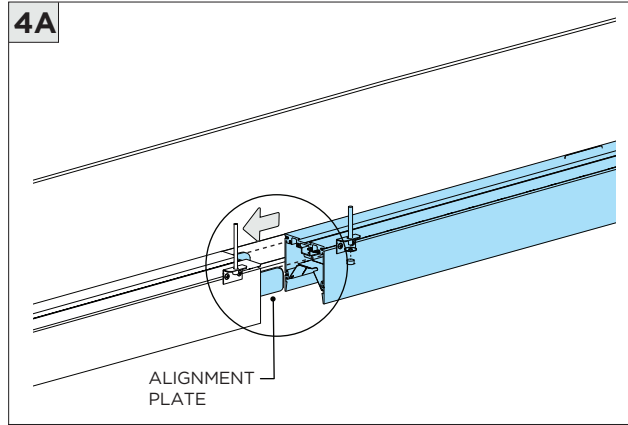
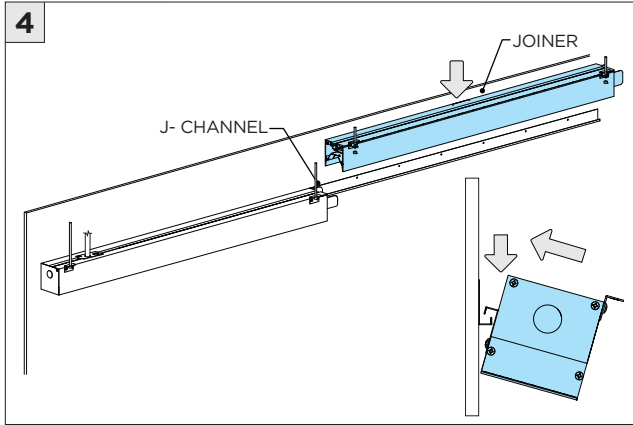

ENDER

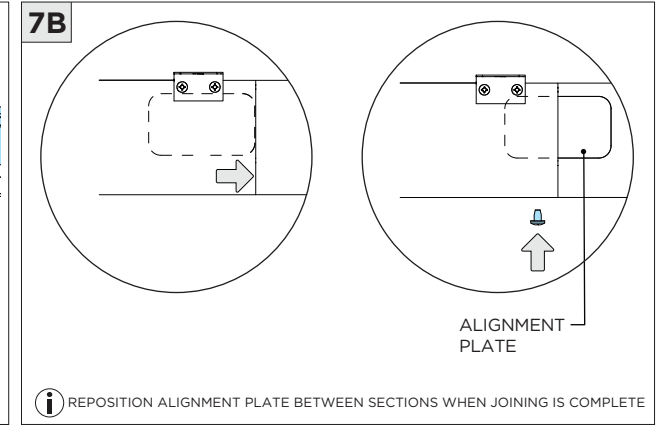
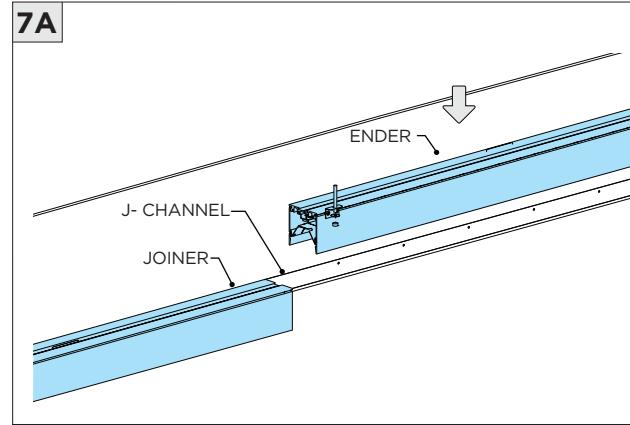
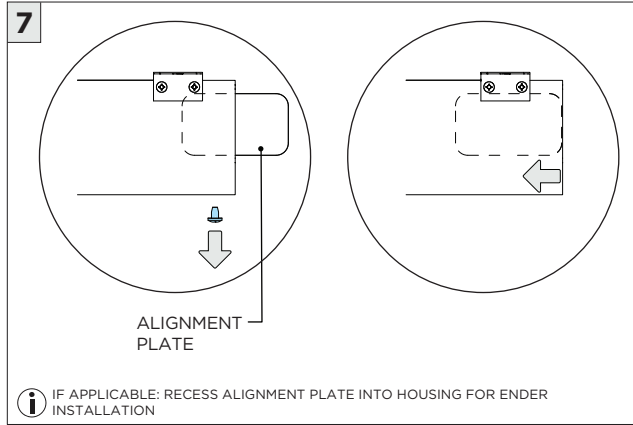

12" END FILLER

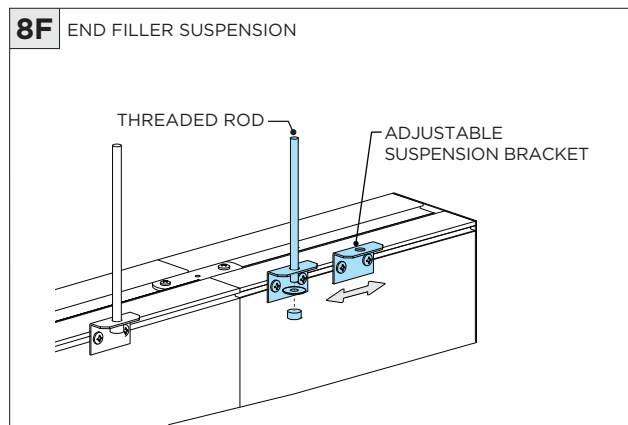
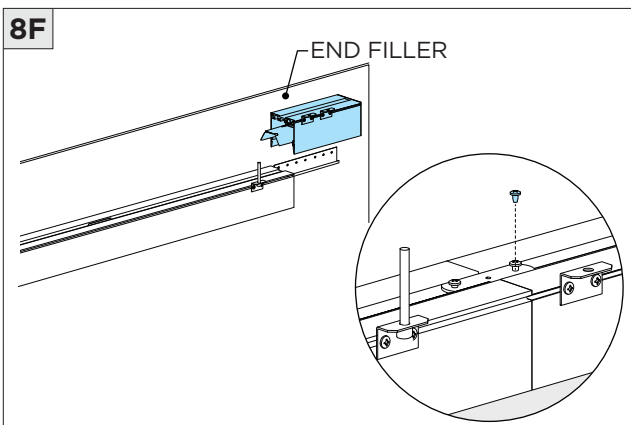
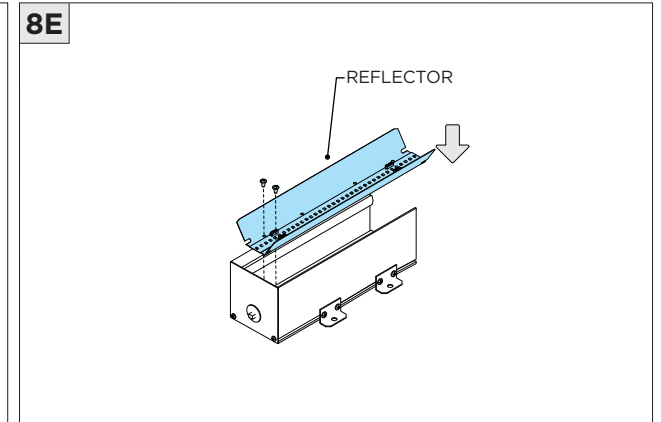
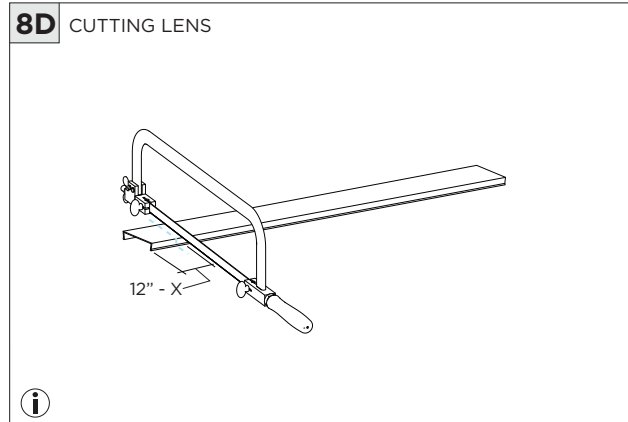
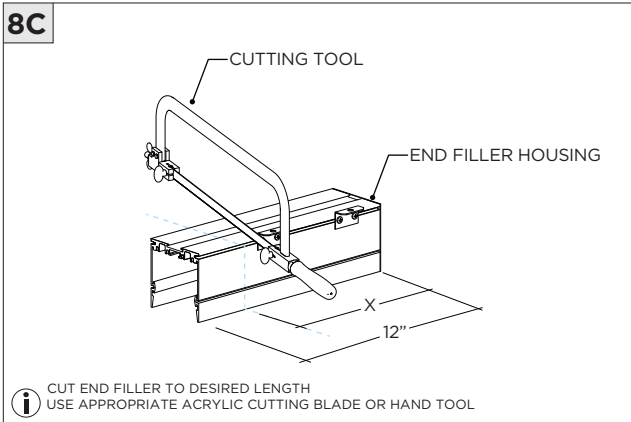
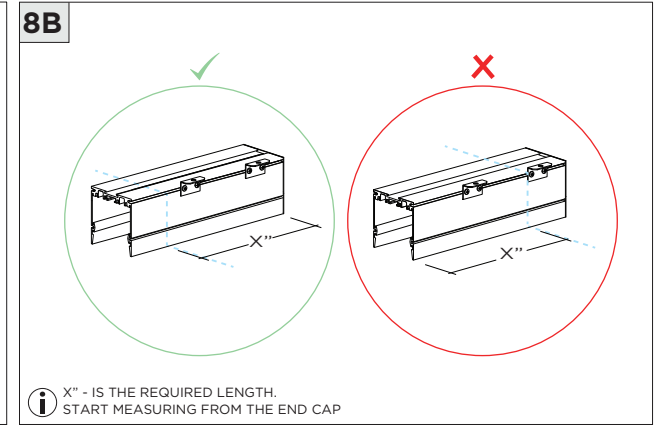
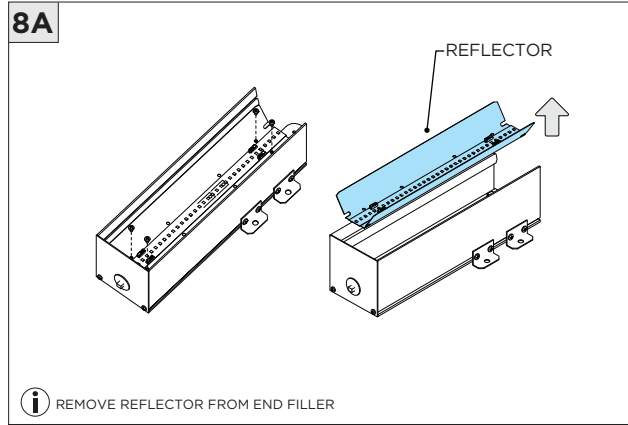
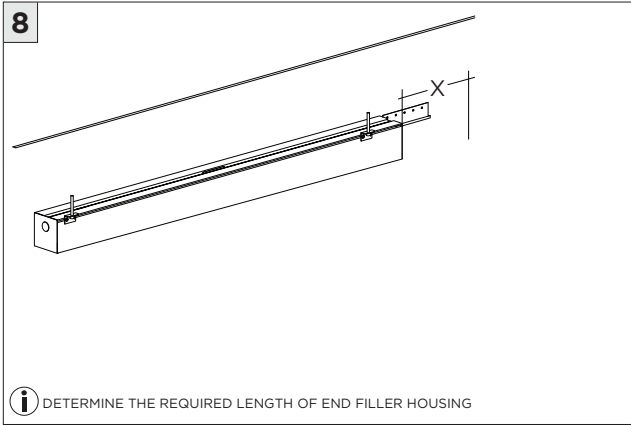

9

REFLECTOR

i LOCK STARTER/JOINER REFLECTORS INTO HOUSING

9A

REFLECTOR

END FILLER REFLECTOR

i OVERLAP REFLECTOR AT END FILLER

10

i TUCK WIRES BACK INTO SLOTS AS SHOWN

11

ADD CEILING

12 ⚠️ APPLIES ONLY FOR TRIMLESS FLANGE

Every 6"

DRYWALL SCREW (BY OTHERS)

i SECURE FLANGES TO CEILING USING APPROPRIATE SCREW FOR HARD SURFACE, PER LOCAL BUILDING CODES.

12A ⚠️ APPLIES ONLY FOR TRIMLESS FLANGE

DRYWALL KNIFE (BY OTHERS)

i APPLY COMPOUND AS REQUIRED FOR TRIMLESS INSTALLATION

i PROTECT LED DURING MUDDING COMPOUND APPLICATION

13

LENS

i FOR ASYMMETRIC LENS ORIENTATION SEE PAGE #5

DRIVER SERVICING

1 FLUSH LENS REMOVAL

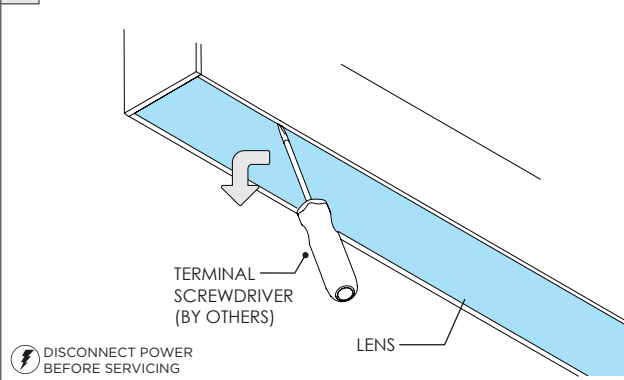

2

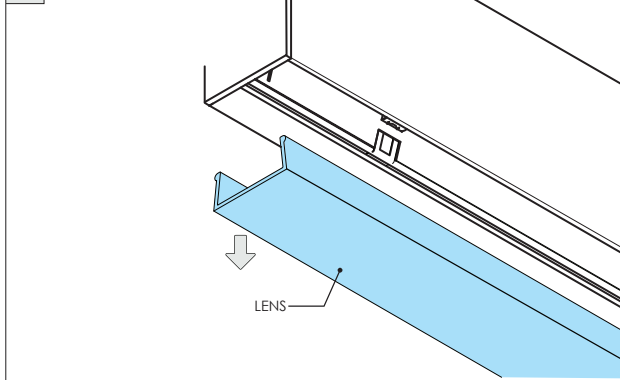

3

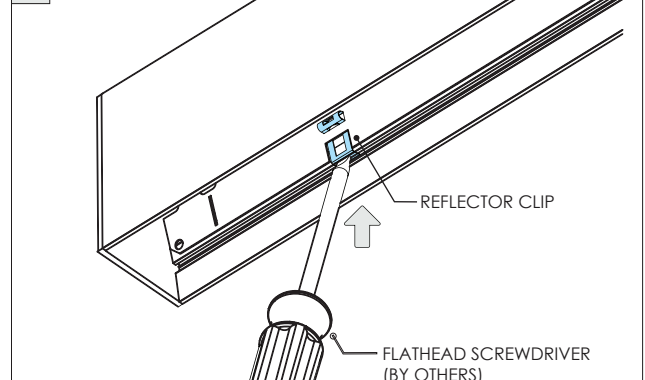

4

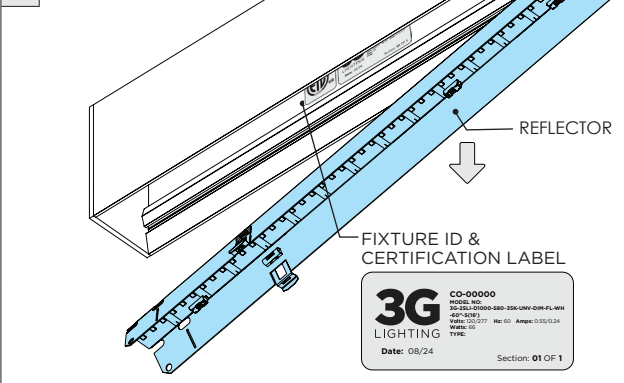

5

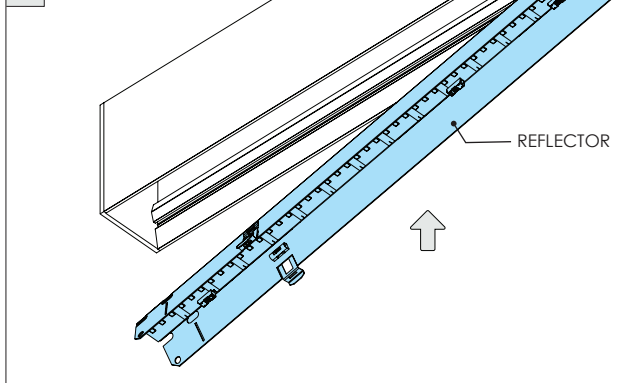

6

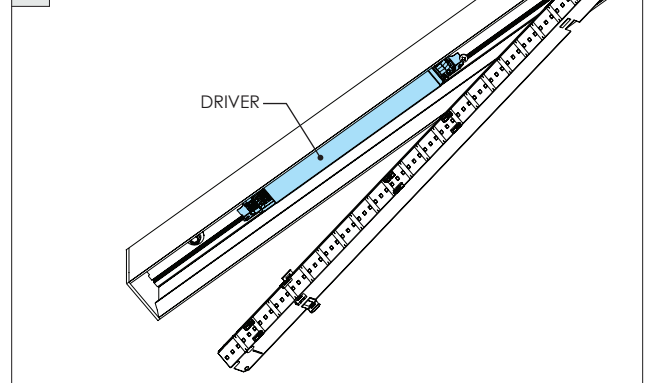

7

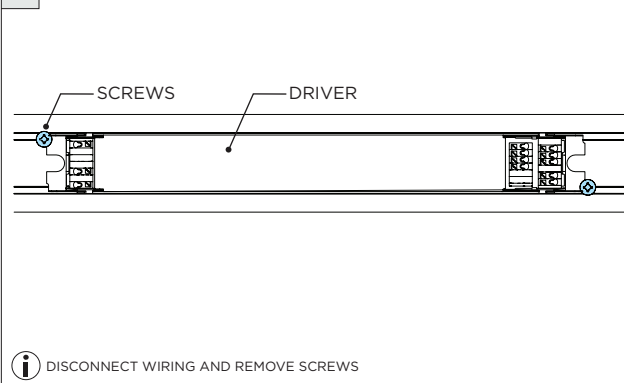

LED SERVICING

