

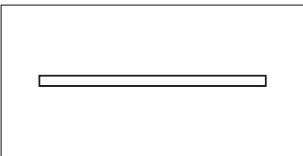

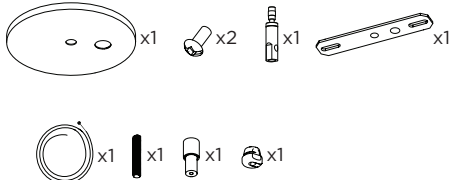
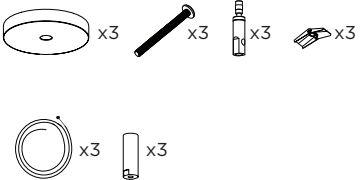
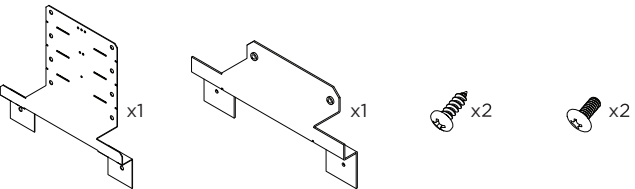

i THE IMAGES SHOWN ARE FOR ILLUSTRATION PURPOSES ONLY AND MAY NOT BE AN EXACT REPRESENTATION OF THE PRODUCT

SHAPES	INCLUDED COMPONENTS	
<p>RECTANGLE</p> 	<p>POWER FEED KIT</p> 	<p>NON-POWER FEED KIT</p> 
<p>FIXTURE JOINING KIT (OPTIONAL)</p> 	<p>HANDLING: THE EDGES OF THE HOUSINGS ARE FRAGILE AND EASY TO DAMAGE ACOUSTIC HOUSING MUST BE HANDLED CAREFULLY</p> <p>CLEANING: DUST CAN BE REMOVED WITH A HAND DUSTER OR VACCUM (WITH BRUSH ACCESSORY) STAINS CAN BE REMOVED WITH A CLEAN WHITE ERASER OR WET WIPE</p>	

INSTRUCTION KEY	INFORMATION
 ADDITIONAL	INSTALLATION SHOULD ONLY BE PERFORMED BY A CERTIFIED ELECTRICIAN
 ATTENTION	REFER TO LOCAL/NATIONAL CODES FOR PROPER INSTALLATION
 POWER ON	FAILURE TO FOLLOW INSTALLATION INSTRUCTION MAY VOID THE WARRANTY DO NOT TOUCH LEDS. LEDS MUST BE PROTECTED FROM MECHANICAL STRESS OR DEBRIS
 POWER OFF	TURN OFF POWER DURING INSTALLATION OR SERVICING

SUSPENSION MOUNTING

24" x 48" PENDANT

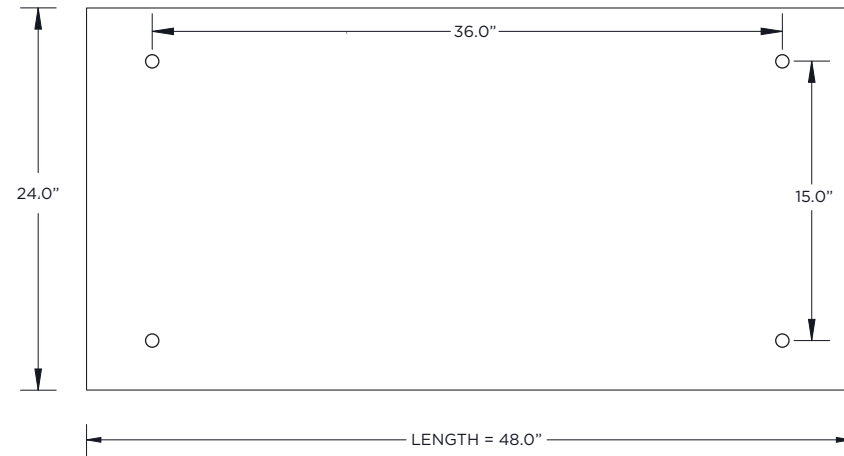
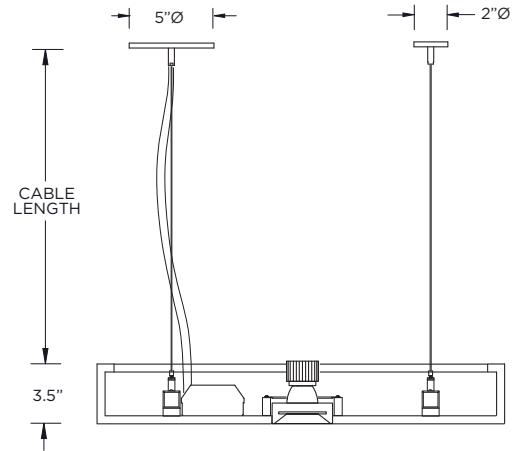

24" x 60" PENDANT

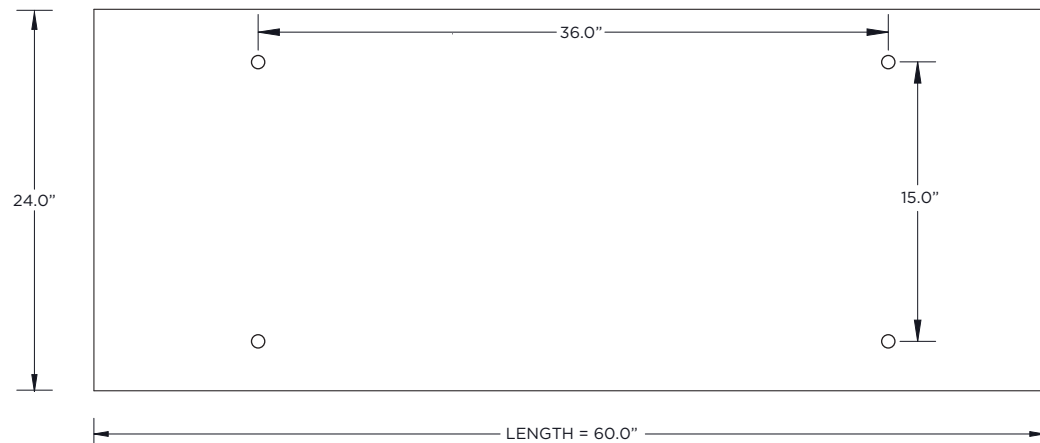
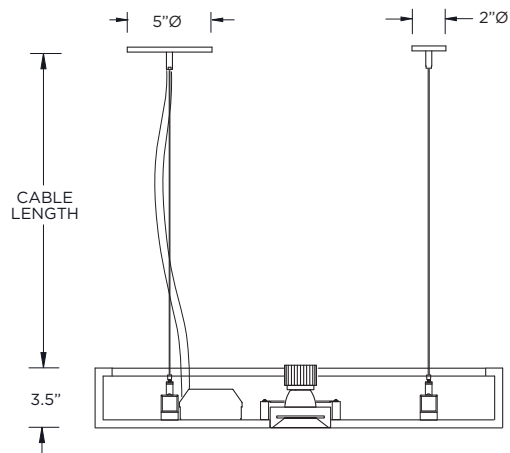

SUSPENSION MOUNTING

24" x 72" PENDANT

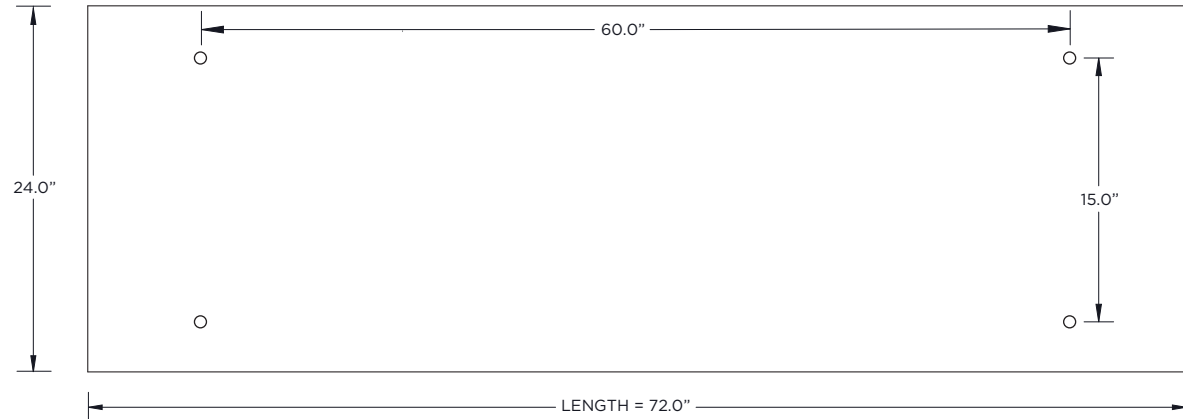
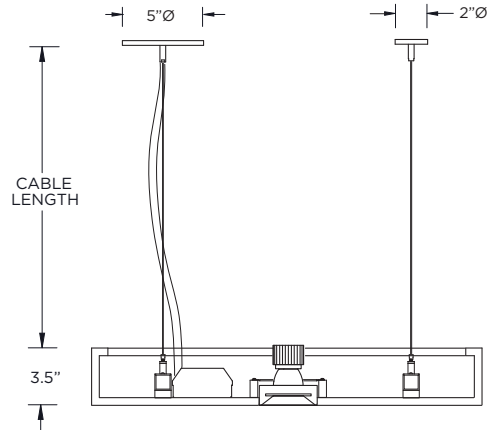

24" x 96" PENDANT

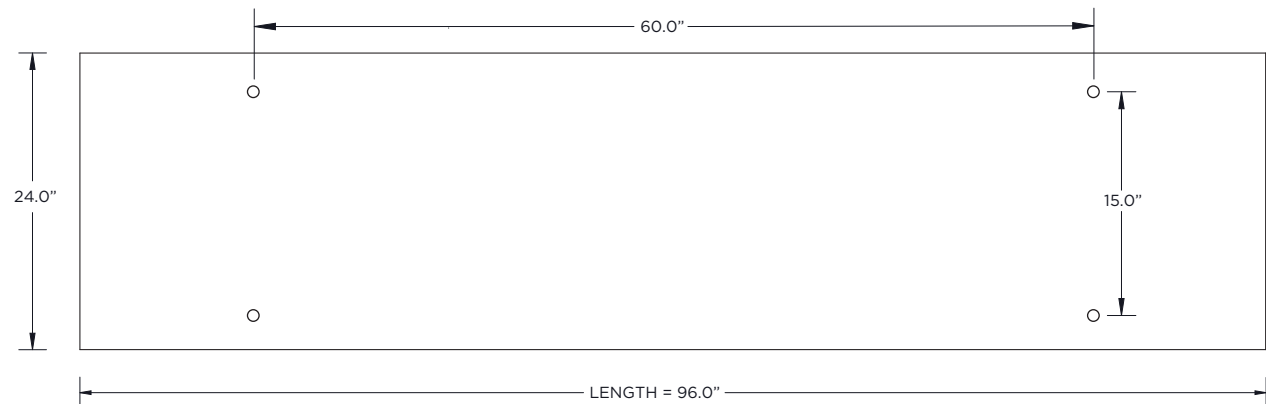
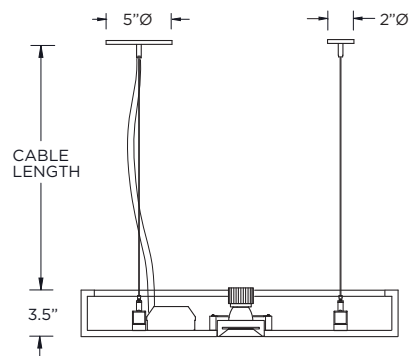

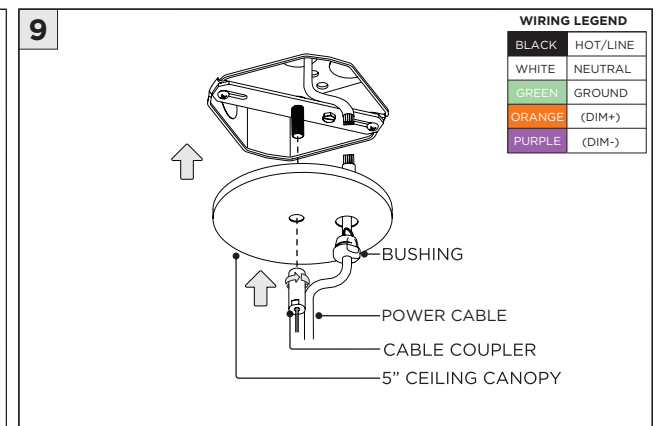
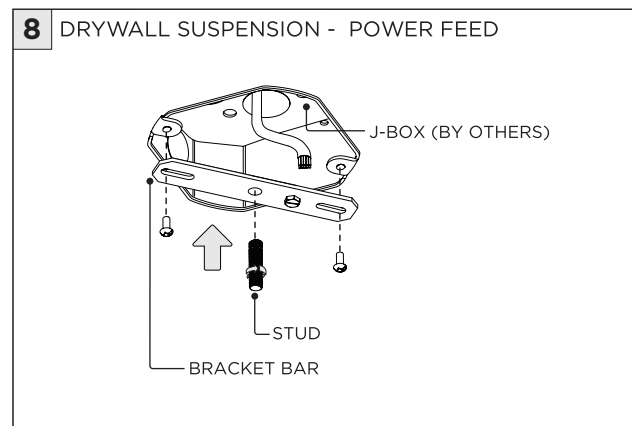
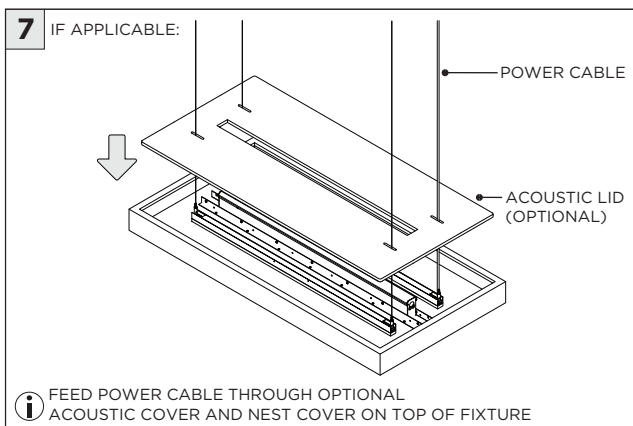
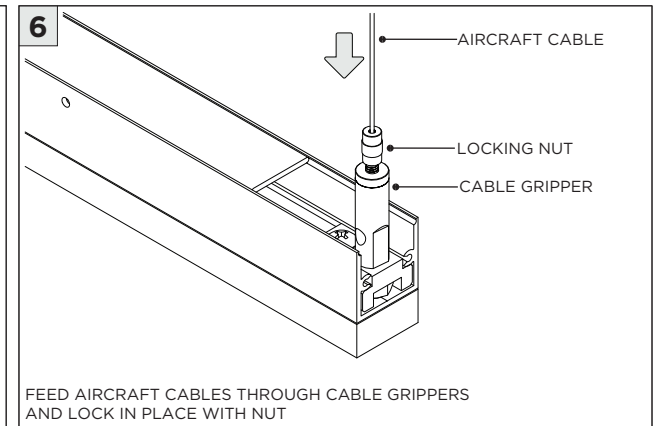
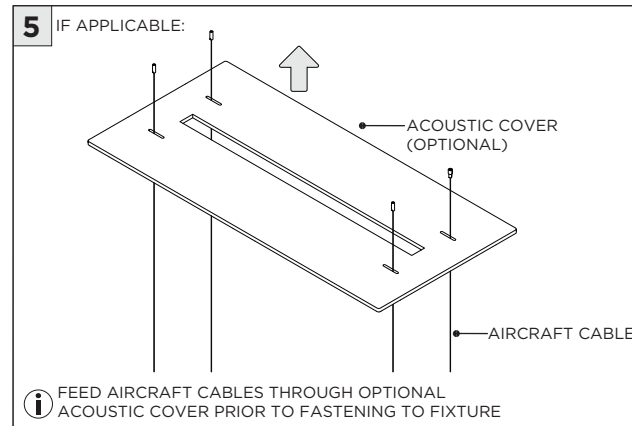
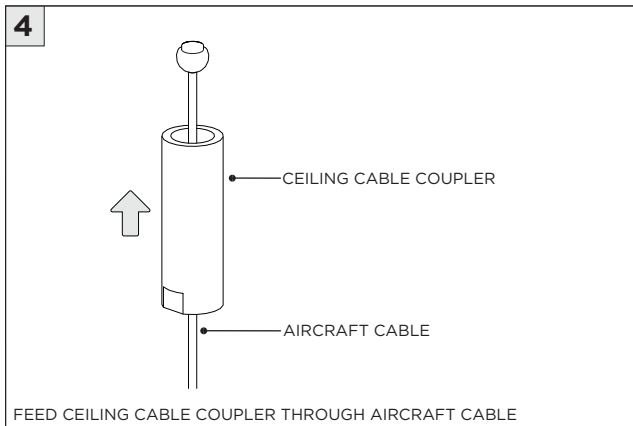
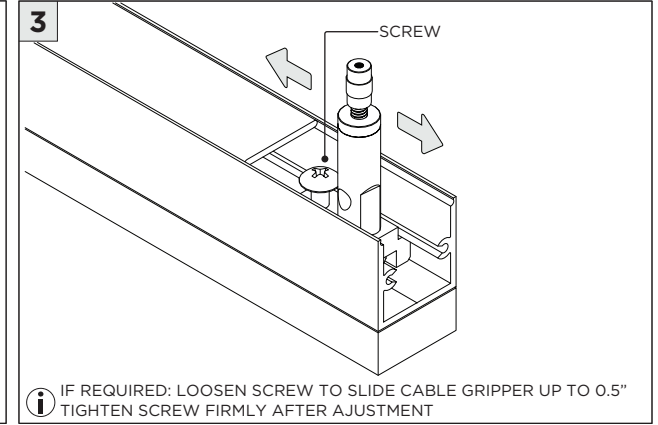
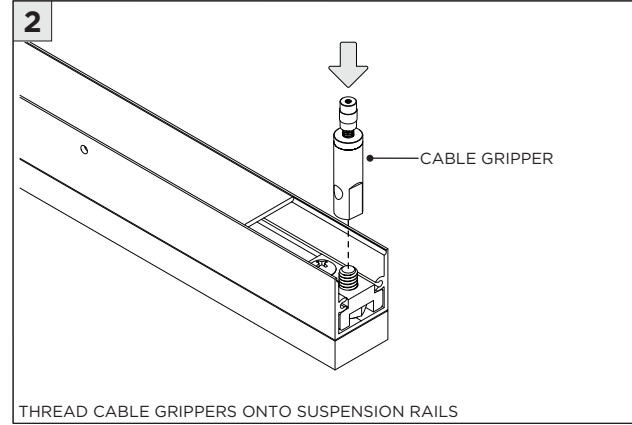
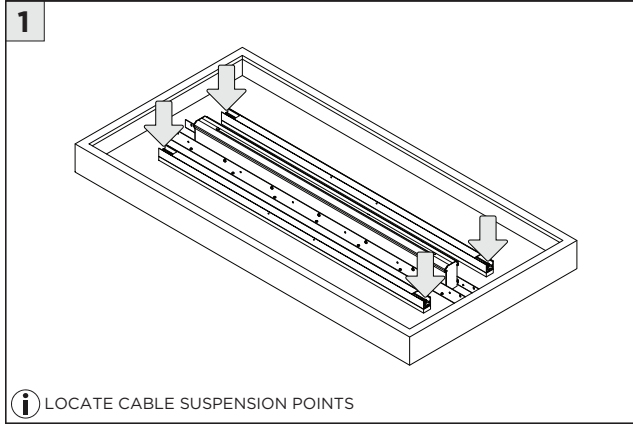

10 DRYWALL SUSPENSION - NON-POWER FEED

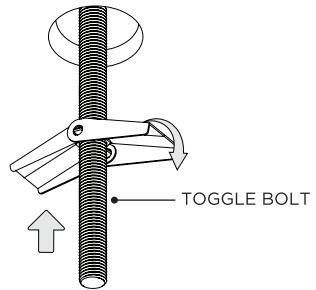

11

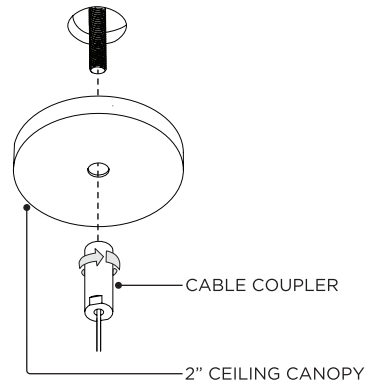

12

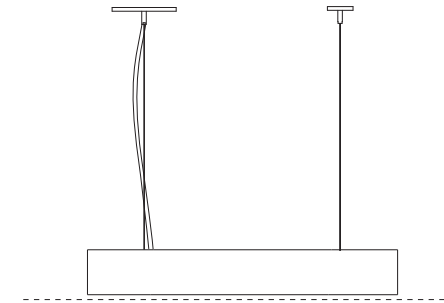

ENSURE FIXURE IS LEVEL
ADJUST AIRCRAFT CABLE LENGTHS IF NECESSARY

FIXTURE JOINING KIT INSTALLATION

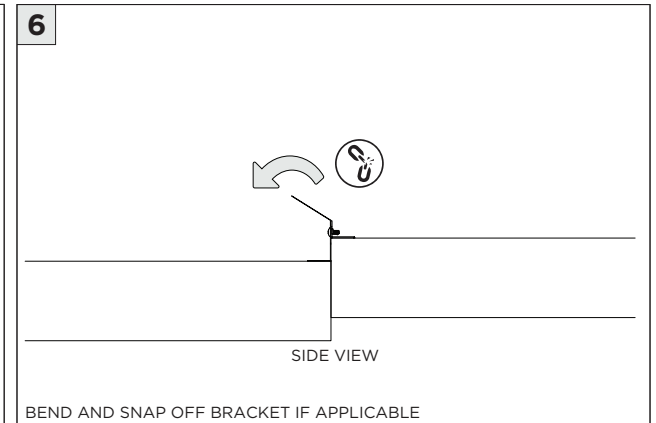
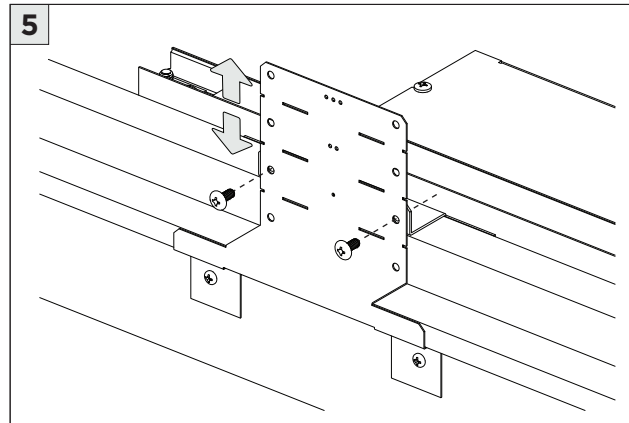
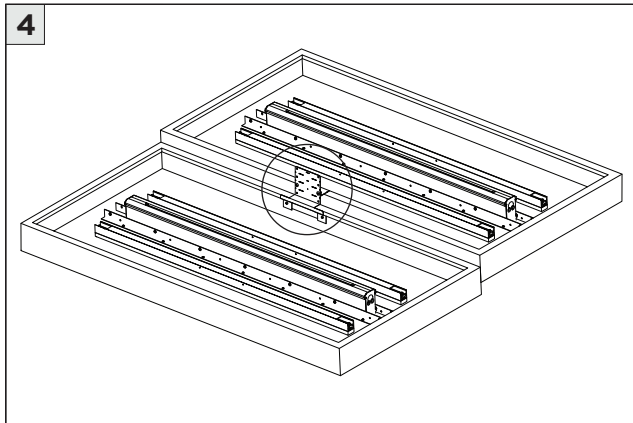
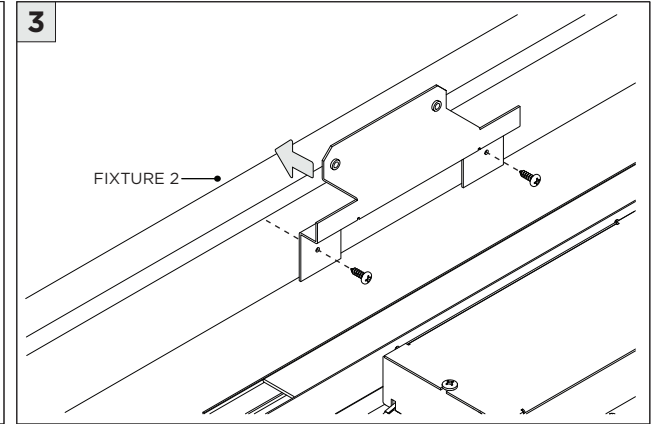
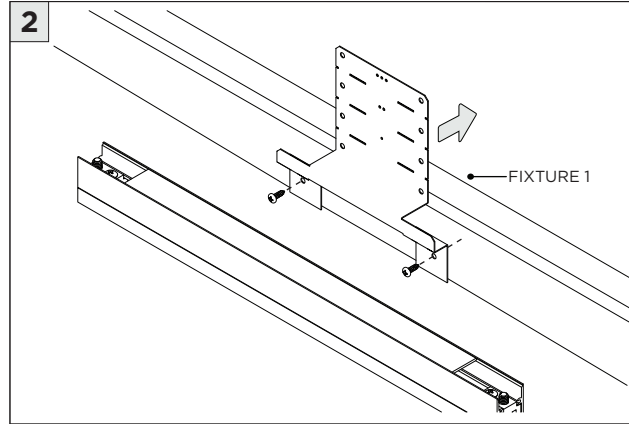
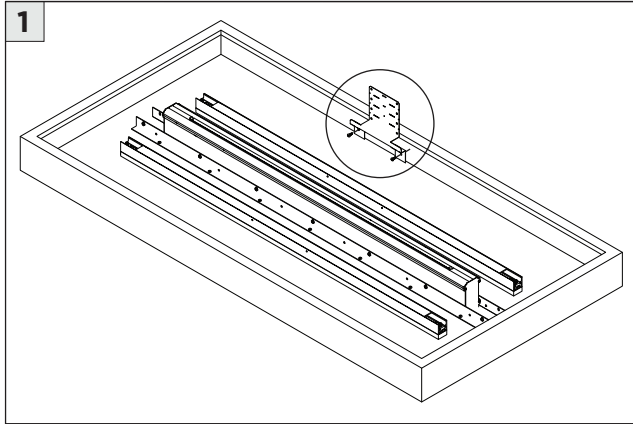

DRIVER SERVICING - LINIA

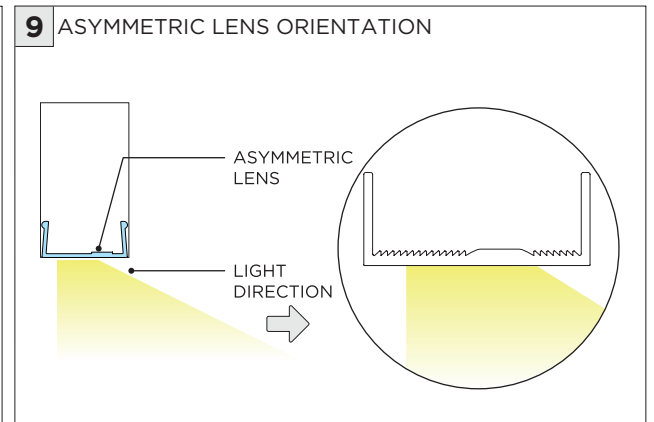
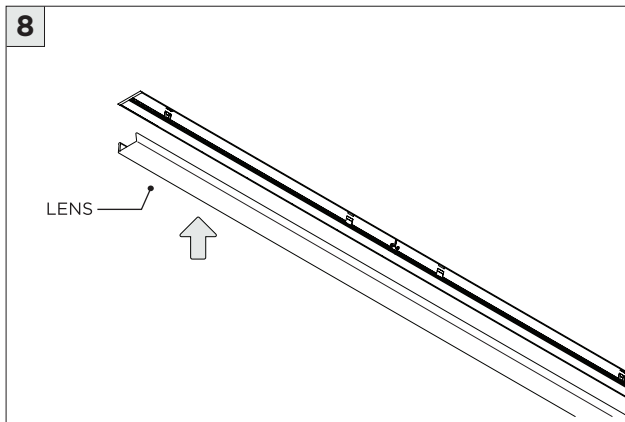
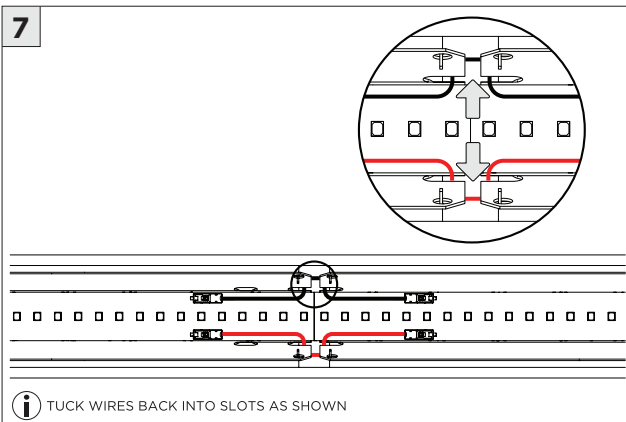
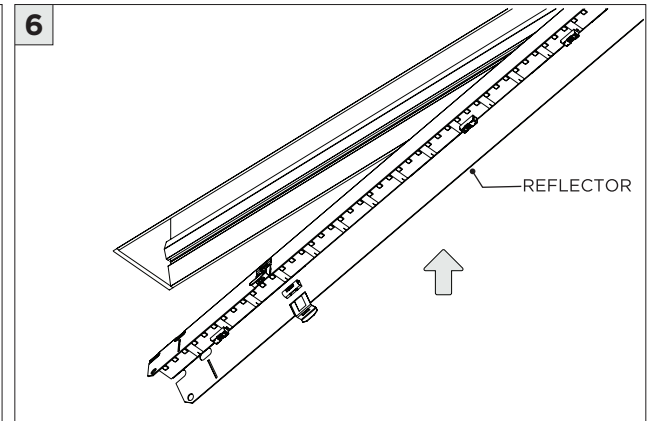
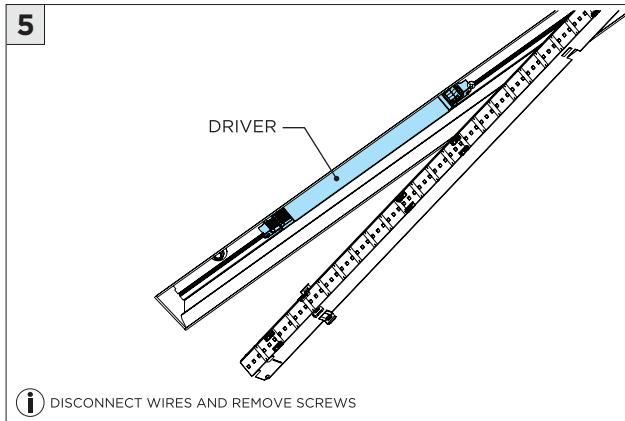
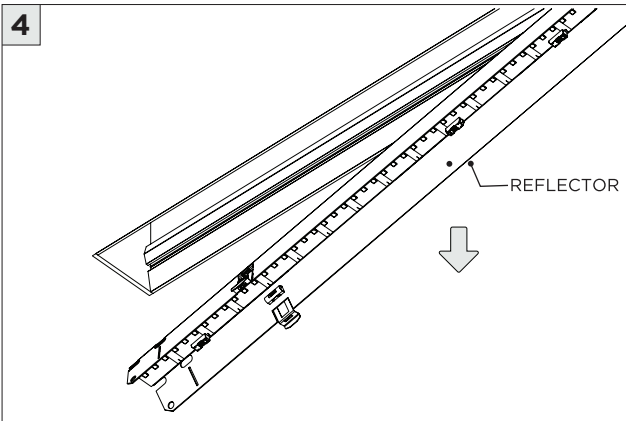
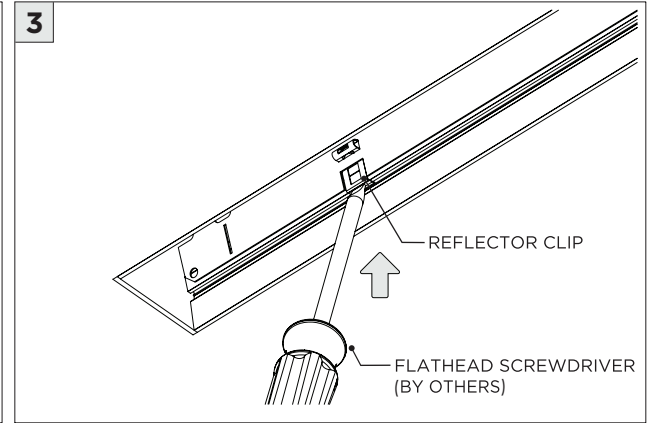
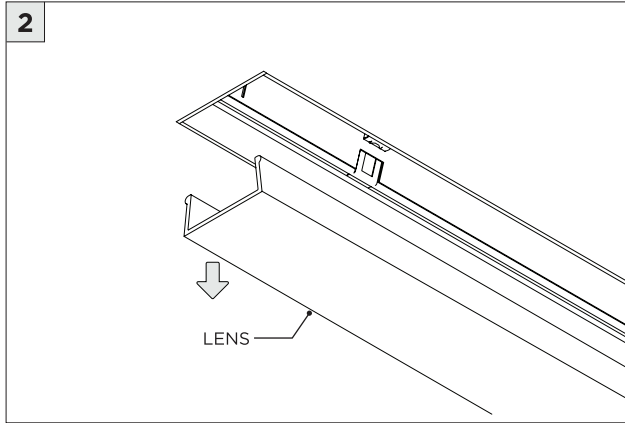
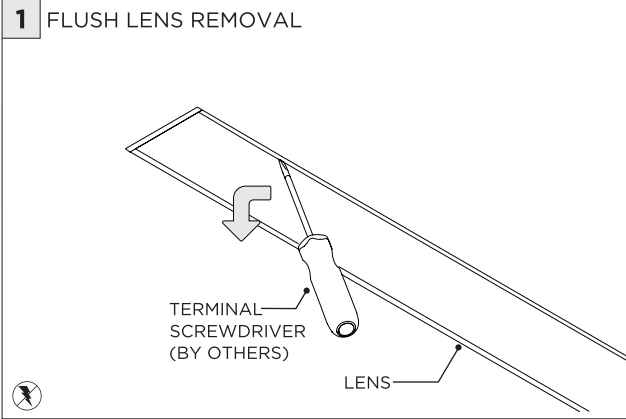

LED SERVICING - LINIA

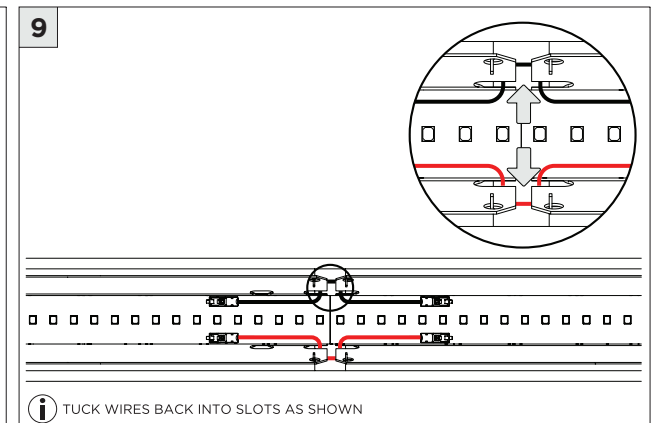
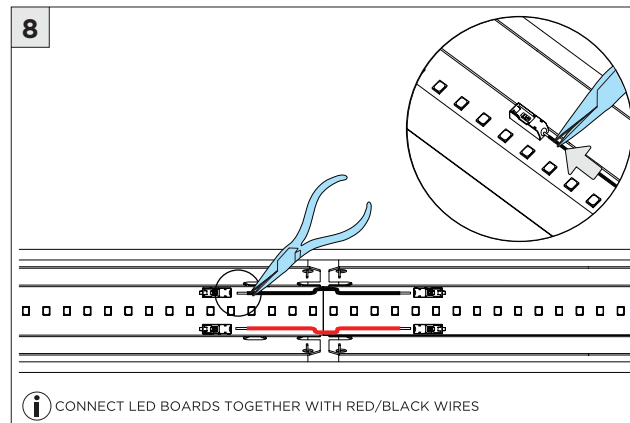
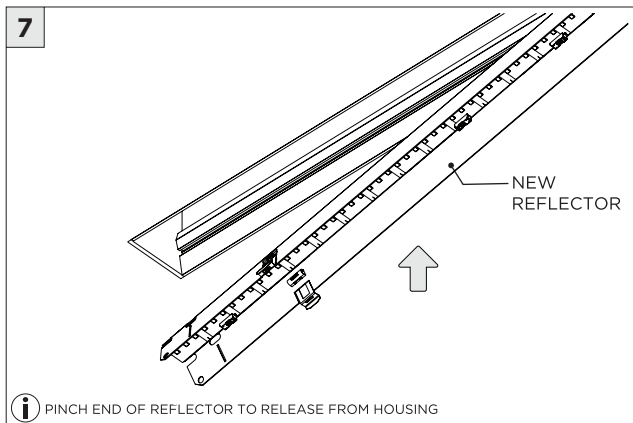
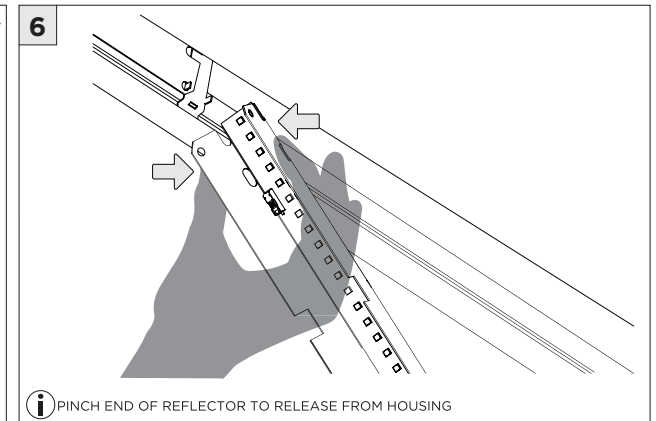
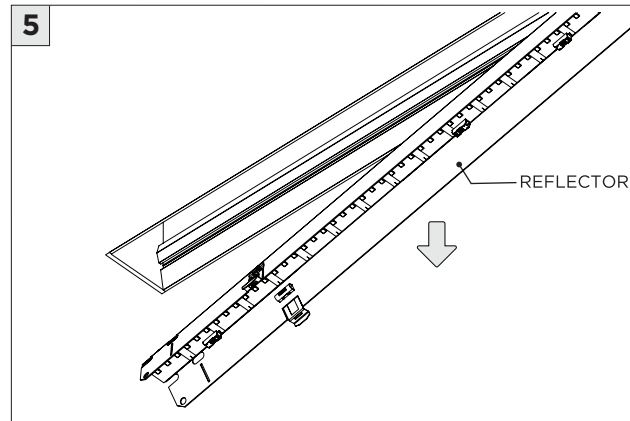
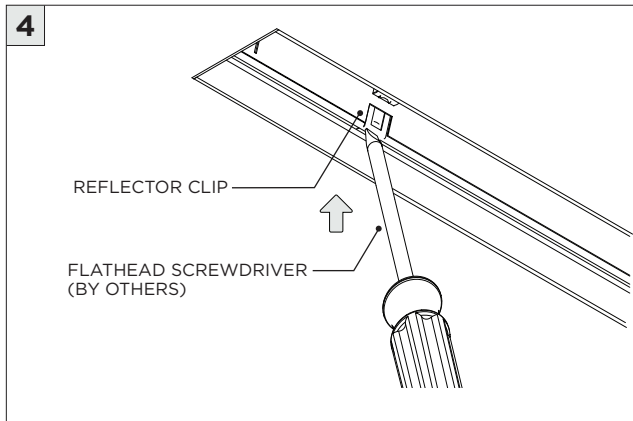
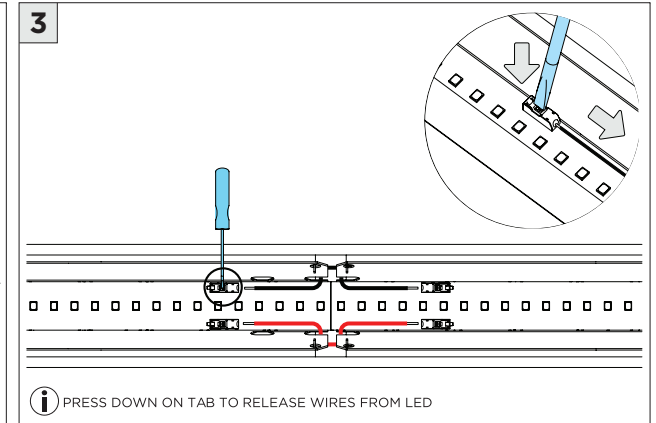
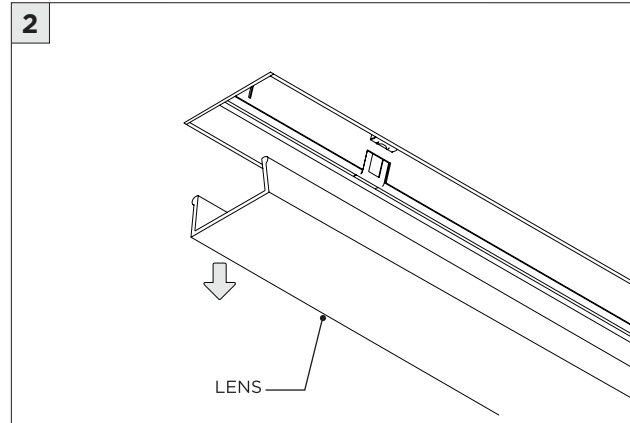
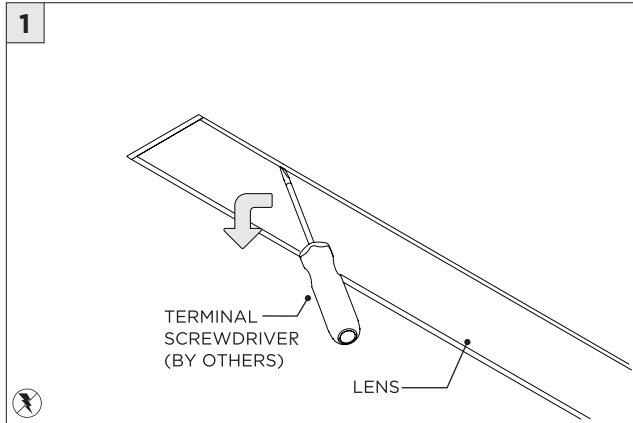

LED SERVICING - LINIA

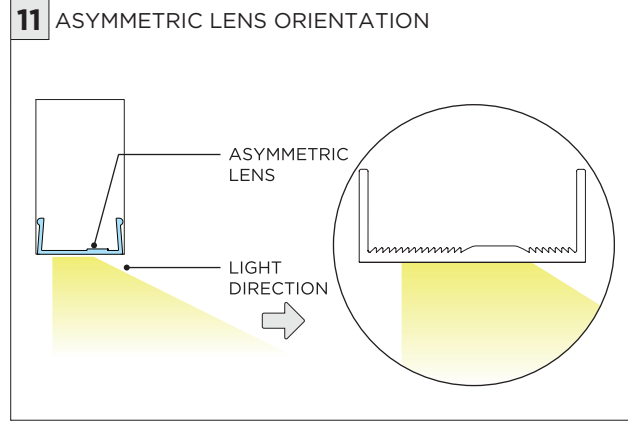
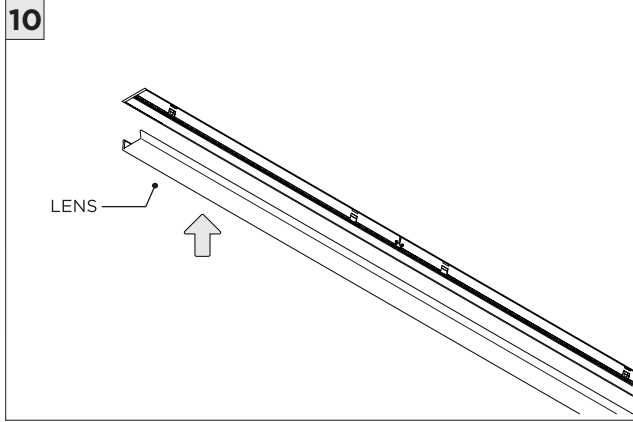

DRIVER SERVICING - ZOIE

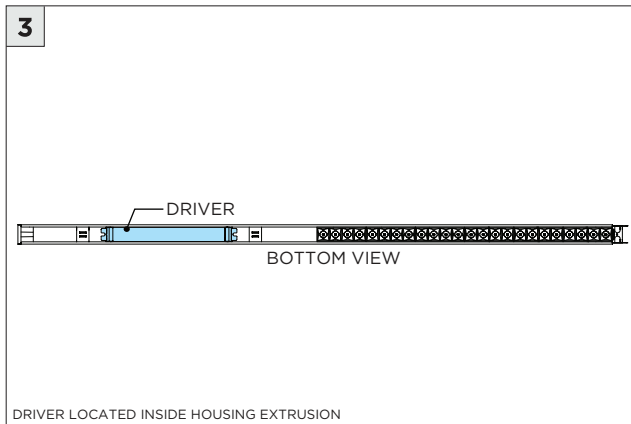
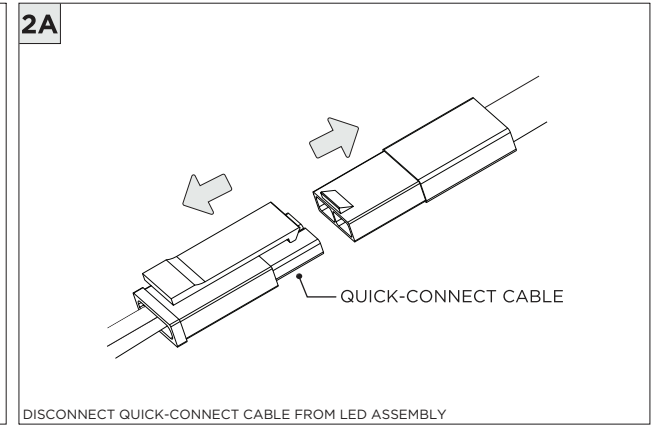
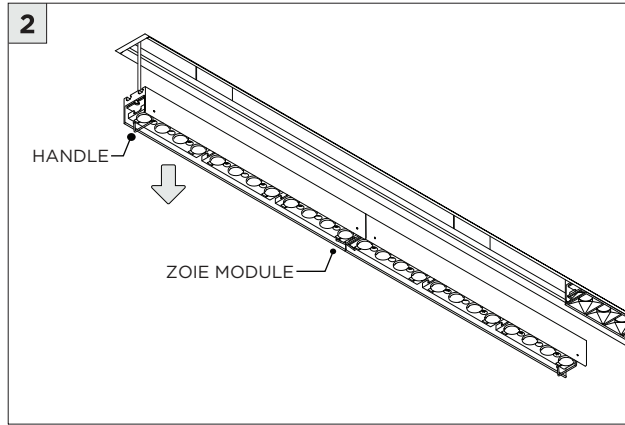
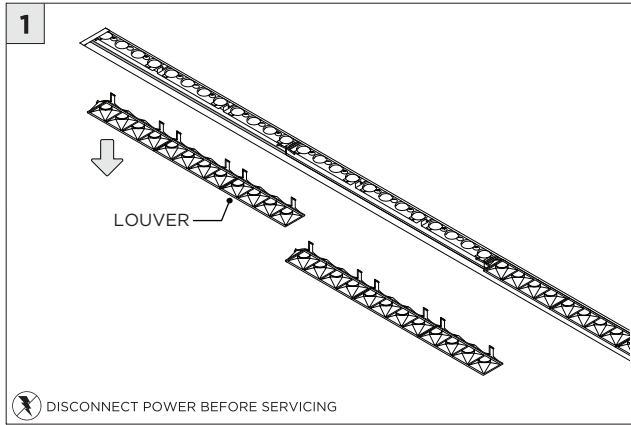

LED SEVICING - ZOIE

